

THERMAL INSTRUMENT CO.

217 Sterner Mill Road, Trevoze, PA 19053

Telephone No. (215) 355-8400

FAX No. (215) 355-1789

Website: www.thermalinstrument.com

Email: office@thermalinstrument.com

INDEX

Page

Instruction Manual –	
General Instructions and Drawings	2-13
General Precautions to be Observed in Installing Flowmeter Wiring.....	14-21
Instruction Manual for _____	
Physical Dimensions of Flow Probe.....	22
Enclosure Installation and Maintenance	23-27
Electrical Condulet Circuit Board	28
Integral Model 9500 Wiring Diagram.....	29
Model 9500 Block Diagram.....	30
Figure 1, 2, 3 and 4	31
Calibration Specification Sheet	
Curves.....	
Calibration Check	
Troubleshooting	

S/N

Thermal Instrument Company

217 Sterner Mill Road, Trevose, PA 19053

Telephone No. (215) 355-8400 FAX (215) 355-1789

Website: www.thermalinstrument.com E-mail: office@thermalinstrument.com

Model 9500 Flow Meter

INSTRUCTION MANUAL



Table of Contents

Description	2
General Features	2
Thermal Mass Flow Measurement	2
Operation	2
Flow Transducer	2
Electronics	3
Installation Instructions	3
Flow Transducer	3
Electronics	
Input Power and Output Signals	3
Mechanical Care	3
Electrical Care	4
Input Power	4
Output Signals	5
Startup Operation	5
Electronics Unit Field Service Details	5
Terminal Board	5
Flow Bridge Voltage Control Board	5
Logic Board	6
Drawing Appendix	7

Thermal Instrument Company Model 9500 Installation and Operation

The instructions to follow will cover almost all installations. Refer to the Drawing Appendix at the rear of this manual for calibration data and any special drawings or instructions for applications where special considerations, such as non-standard piping configurations or unusual power or signal requirements are encountered.

Description

General Features

There are two physical parts of the meter; the flow transducer and the electronics assembly. The flow transducer is either a probe (Model 62) or an in-line section (model 600) supplied with fittings to mate with the process plumbing. The flow transducer is connected to the electronics housing.

There are many features incorporated in this meter which are covered in this manual. Please read the manual carefully to prevent accidental damage to the meter in installation and operation.

Thermal Mass Flow Measurement

The basic mechanism of the measurement is implemented by heating one or more spot(s) on the wall of the fluid conduit to a precise temperature and measuring the power required to maintain that temperature. There is a direct relationship between the fluid mass flow rate and the heater operating power. This relationship is determined by actual (or equivalent) flow in duplicate conditions to the application.

The utilization of heat transfer to measure mass flow rates is a technique dating back to the early 1900's. It has been only since 1959 when Thermal Instrument Company pioneered with industrial quality devices for both gas and liquid flows that the method has gathered universal acceptance.

Operation

Please refer to the block diagram Figure 1 as you read through the following description of operation.

Flow Transducer

The Thermal Instrument Company meter uses a unique compound bridge circuit which measures and controls the temperature of a precision RTD (Resistance Temperature Detector) bonded to the dry side of the fluid conduit.

The power required to maintain this temperature is proportional to the mass flow rate of the fluid. Unfortunately, this relationship is highly non-linear. For some liquids over limited flow ranges the relationship is logarithmic. In general though, some form of linearization (curve straightening) is necessary for a practical instrument.

Also, since the heat transfer characteristic of all fluids (and almost any measurement technique) is temperature sensitive, some method of temperature compensation must be included in the instrument.

Electronics

These functions are accomplished on the Bridge Voltage Control Board shown in Figure 2. The output signal is passed to the Logic Control Board (Figure 3) where the non-linear signal is digitized. This digital value is used to look up the corresponding flow value in an EEPROM (Electrically Erasable Programmable Read-Only Memory). The linearized value is then used to drive an LED flow rate display, an 8-digit Totalizer and the 4-20 mA current output flow signal.

The Logic Control Board incorporates a micro-processor which controls the data flow and modifies the calculations according to parameters stored in EEPROM. The microprocessor also controls the communications link between the meter and a PC. This link is used to monitor and change the operating factors mentioned above in the Features section.

Installation Instructions

Flow Transducer

For our in-line meters, Model 600-9, the meter can be mounted in either a horizontal or vertical pipe lines. However, when mounted in vertical piping, the flow must be upward.

For our probe meters, Model 62-9, the meter can be mounted in either a horizontal or vertical pipe lines. If mounted in vertical piping, the flow can be going upward or downward, however, if mounted in vertical piping with liquid flow going down, ensure that the line stays full of liquid.

Any special piping configurations requested by the customer, to be included in the factory calibration, must be duplicated for best accuracy.

Normally, an inline meter should be installed in an unobstructed straight line. The flow should enter at the port marked "IN" and exit at the port marked "OUT". This line should preferably be the same diameter as the meter tube or pipe. The straight section should have a minimum of ten (10) diameters ahead of the meter and an unobstructed straight length of five (5) diameters after the meter. **Where physical conditions prevent this, inform us in advance and we will calibrate the meter under actual operating conditions.**

The same installation conditions apply to the Model 62 Probe transducer. The probe must be rotated so that the index arrow etched on the probe fitting faces toward the flow.

Input Power and Output Signals

General Considerations

Mechanical Care - Be careful of the enclosed electronics when removing the conduit cover. **After the initial installation, never open the conduit when power is connected.** Gently lift the cover from the electronic assembly and put it in a safe location where dirt cannot get inside or, if the display option has been selected, where dirt can get on the inside of the viewing window. When replacing the cover take care that the display legend plate is centered on the display and that the cover window lugs do not hit the legend plate in the last two or three turns of the cover.

Electrical Care - Wire size selected for all connections should be the minimum allowed by

plant regulations since power consumption is small and space inside the conduit housing is at a premium. When snaking the wires around the electronic assembly be careful of the protruding parts. The parts are capable of withstanding some abuse but be careful.

Input Power

As shown in Field Wiring Drawing No. TIC-436-1, the input power is fused at ½ ampere (slow blow). Spare fuses are supplied in the installation kit. They are readily available from DigiKey (1-800-344-4539) as Part Number WK4041BK-ND or any other electronic supplier handling Wickmann TR5 Sub-Miniature Fuses (UL 248-14) or equivalent.

110/220 VAC - The electronics may be powered by either 110 VAC or 220 VAC but the selection is made by jumpers not accessible in the field. As shown on the Field Wiring Drawing No. TIC-436-1, the HI line is connected to Terminal Block 1, point 1 at the top. The LO (neutral) line is connected to point 2 and the earth line is connected to point 3.

Take special note that the two two-point terminal blocks are for the output signals. DO NOT CONNECT HIGH VOLTAGE POWER TO THESE BLOCKS. There are protective PolySwitch breakers on the output signal lines and they will “open” up if overloaded but circuits can still be damaged.

24 VDC - (22 volts DC min, 30 volts DC max) - As shown on the Field Wiring Drawing No. TIC-436-1, the positive line is connected to Terminal Block 1, point 1 at the top. The negative line is connected to point 2 and the earth line (when used) is connected to point 3.

Take special note that the two two-point terminal blocks are for the output signals. DO NOT CONNECT HIGH VOLTAGE POWER TO THESE BLOCKS. There are protective PolySwitch breakers on the output signal lines and they will “open” up if overloaded but circuits can still be damaged.

The 24 volt version of the Model 9500 can be connected in a three-wire configuration (four-wire with temperature transmission). In this configuration the current signal common to the flowmeter is eliminated and the common line for the output signal is connected at the 24 volt source negative. If plant regulations permit, the three-wire configuration could be two wires plus shield for the common.

Output Signals

Terminals are provided for **local instrument powered** two-wire signals (positive and common). If the Temperature Transmission option has been provided, a single wire common connection may be used or two two-wire cables may be run. There are protective PolySwitch breakers on all output signal lines and they will “open” up if overloaded but circuits can still be damaged. When power is on if there is zero output current (there should be at least four mA even through a current meter) disconnect the field wiring and check the terminal block points for a voltage. Presence of a voltage (typically 20 to 30 volts) with no current flow indicates that the PolySwitch breakers have been tripped. Power must be turned off if the PolySwitch breakers are tripped in order for them to reset. They do not need to be replaced as a fuse. Maximum load resistance is 500 ohms.

Flow - The 4-20 mA flow signal is at Terminal Block 2, the positive connection on point 1 (at the top of Block 2) and the negative on point 2. The output current signal is 4 mA at

zero flow and 20 mA at 100% of rated flow.

Temperature (optional) - The 4-20 mA temperature signal is at Terminal Block 3, the positive connection on point 1 (at the top of Block 3) and the negative on point 2.

Startup Operation

With all connections having been completed and tested, a short but fast flow rate should be obtained in order to clean gas bubbles and impurities from the flow tube.

CAUTION - Flow and transducer must be within 50 °C of operating temperature before power is applied. Sensors may be damaged if transducer temperature is below this limit and/or calibration may not be accurate.

Apply power and allow a ten (10) minute warm-up period.

The Appendix to this manual contains the Flow Calibration Curve which correlates the flow rate versus the indication for this meter. When a factory calibration is provided it should not be necessary to perform a calibration in the field. Field calibration instructions are provided if it should be decided to use the meter with a different fluid.

Electronics Unit Field Service Details

Terminal Board (Figure 1 and Figure 2)

Figure 1 shows the component configuration for the two field wiring boards. Figure 2 depicts the obsolete model and is shown for information purposes only.

All field wiring is made to the terminal board. There are two (optionally 3) terminal blocks. Connect the input power to the three-position block TB1 according to TIC-436-1 the field wiring diagram. Terminal Block TB2 carries the 4-20 mA flow signal and, if optionally ordered, TB3 carries the 4-20 mA signal for the specified temperature range. Both current signals require a loop with a maximum resistance of 500 ohms. The signals are powered by the internal electronics and must not be connected to an external power supply.

Ferrite beads RF1 and RF2, capacitors C3 and C4 and RF3 through RF6 provide EMI (Electro-Magnetic Interference) filtering for all external wiring paths.

Diodes D1 and D2 and Polyswitches PS6 and PS7 (auto reset thermal fuses) provide circuit protection against accidental connection to an external voltage.

Flow Bridge Voltage Control Board (Figure 3)

The flow bridge voltage control board controls the flow transducer sensor and provides the non-linear flow signal to the logic board.

In calibration, potentiometer R2 is set to balance the temperature sensor with the flow sensor at the lowest temperature in the application range. A second pot R11 is set to balance the bridge at the high extreme of the application temperature range. **These two adjustments are determined in calibration and should NOT be changed.**

Logic Board (Figure 4)

The logic board converts the non-linear analog flow signal to a digital value, determines the linear equivalent from the data stored in an Electronically Programmable Read Only Memory (EPROM), runs an 8-digit totalizer and outputs the linear flow data as an analog signal (4 to 20 mA) and a 5½ digit flow rate display. The totalizer can be reset with the push-button on the Logic Board or by remote device through the digital programming interface.

R7 is adjusted so that the voltage on TB5 pin 1 is equal to the zero flow voltage from the flow bridge.

Adjustment is then made to R11 so, when the maximum voltage is applied to the S+ input, the voltage at TB5 pin 3 equals 4.096 volts.

Potentiometer R13 provides the 4 mA adjustment for the output current signal while R15 provides the 20 mA adjustment.

Drawing Appendix

Drawings	
Figure 1 Block Diagram	8
Electronic Assembly	
Figure 1 - Terminal Boards	9
Field Wiring Diagram 24VDC.....	10,11
Field Wiring Diagram 110VAC	12,13
General Wiring Precautions	14,15
Adalet Fittings sizing and ratings.....	16-21
Troubleshooting hints	35-38

REV	DESCRIPTION	DATE	DRN. BY	ECN #
A	RELEASE TO PRODUCTION	4-29-02	<i>RLM</i>	

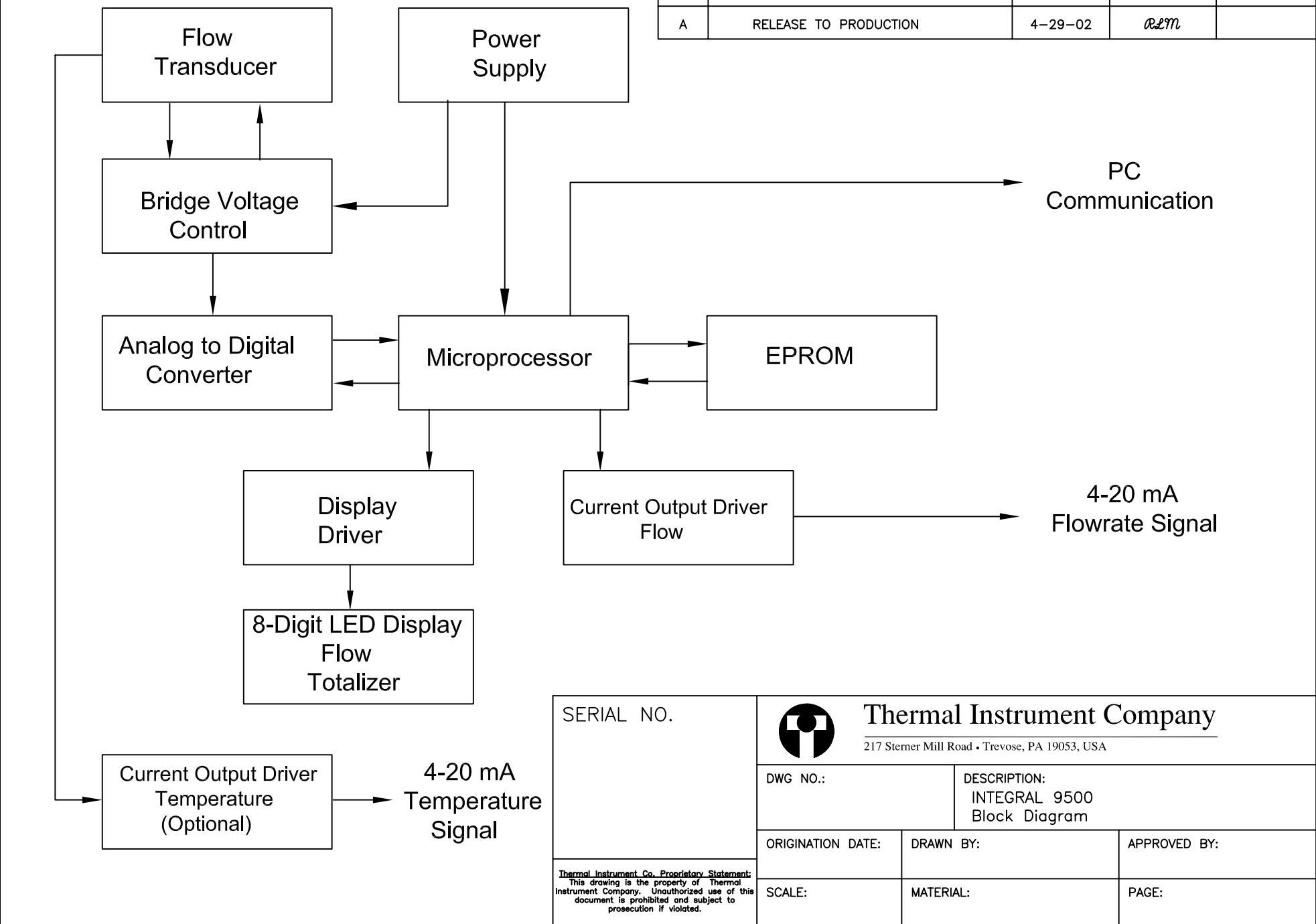

SERIAL NO.	 Thermal Instrument Company 217 Sterner Mill Road • Trevose, PA 19053, USA		
	DWG NO.:	DESCRIPTION: INTEGRAL 9500 Block Diagram	
ORIGINATION DATE:	DRAWN BY:	APPROVED BY:	
<small>Thermal Instrument Co. Proprietary Statement: This drawing is the property of Thermal Instrument Company. Unauthorized use of this document is prohibited and subject to prosecution if violated.</small>	SCALE:	MATERIAL:	PAGE:

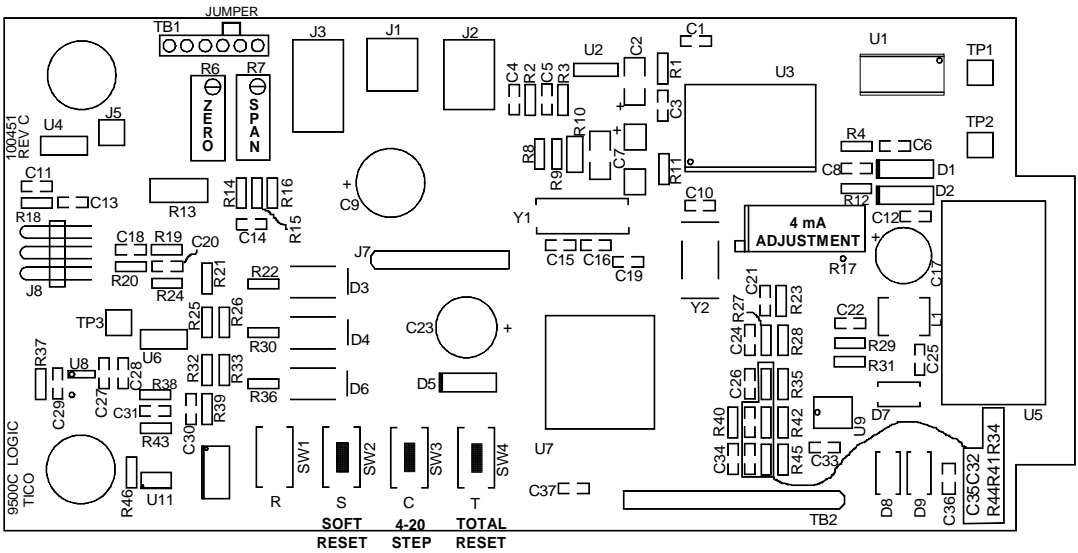
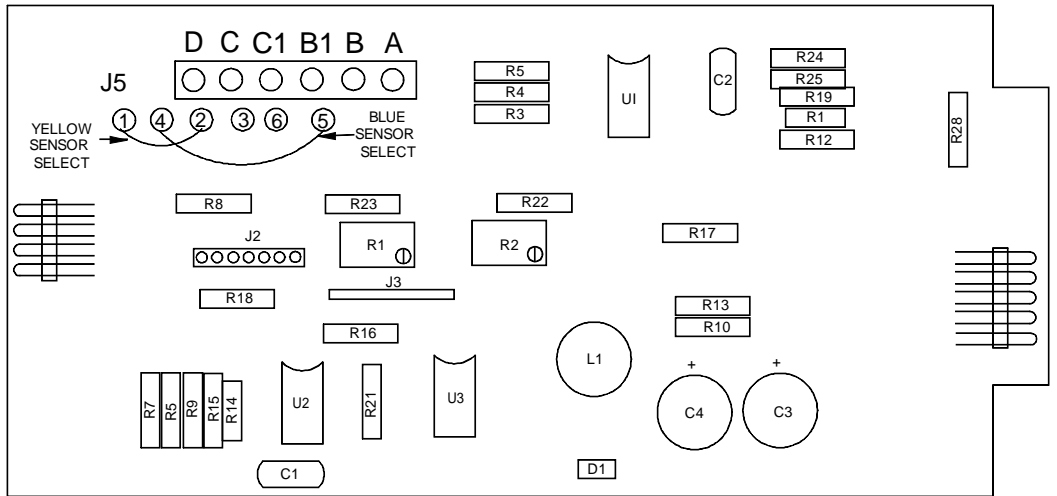
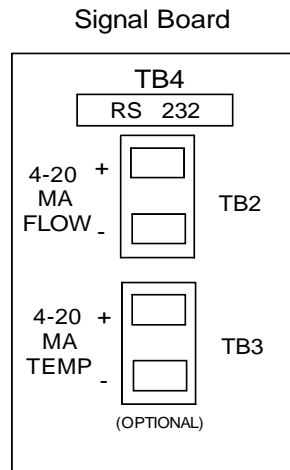
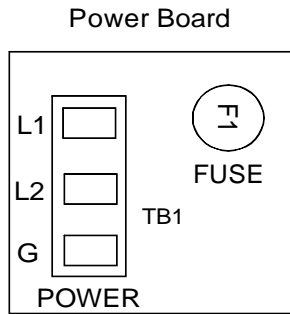

REV	DESCRIPTION	DATE	DRN. BY	ECN #
A	RELEASE TO PRODUCTION	4-28-02	<i>ALM</i>	

ELECTRICAL CONDULET

3/4" NPTF

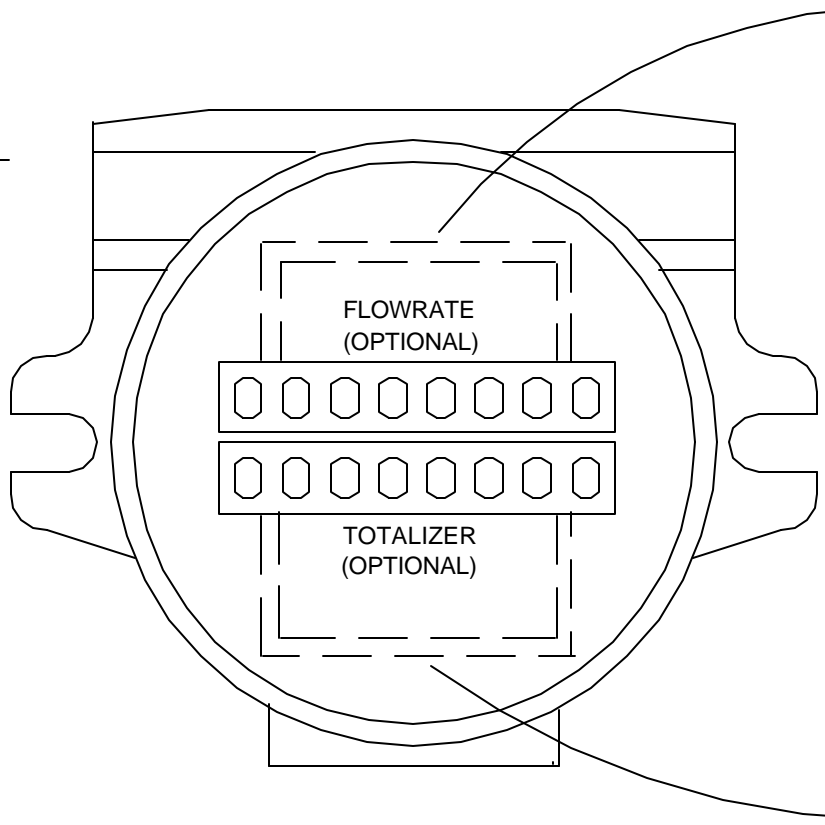

Power Board

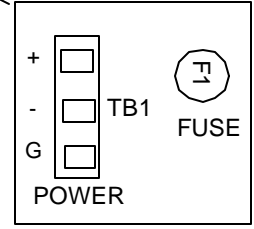

Signal Board

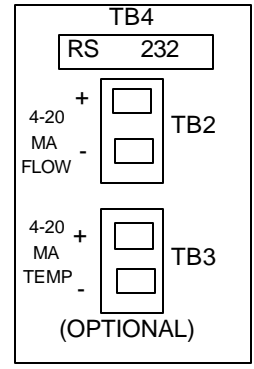

24 VDC

SERIAL NO.

Thermal Instrument Co. Proprietary Statement
This drawing is the property of Thermal Instrument Company. Unauthorized use of this document is prohibited and subject to prosecution if violated.



Thermal Instrument Company

217 Sterner Mill Road • Trevoze, PA 19053, USA

DWG NO.:		DESCRIPTION: INTEGRAL 9500 24 VDC WIRING DIAGRAM	
ORINATION DATE:	DRAWN BY:	APPROVED BY:	
SCALE:	MATERIAL:	PAGE:	

1.0

TERMINAL BOARDS

REV	DESCRIPTION	DATE	DRN. BY	ECN #
A	RELEASE TO PRODUCTION	4-29-02	<i>RLM</i>	

POWER BOARD

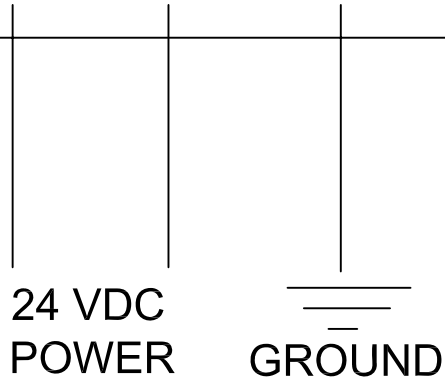
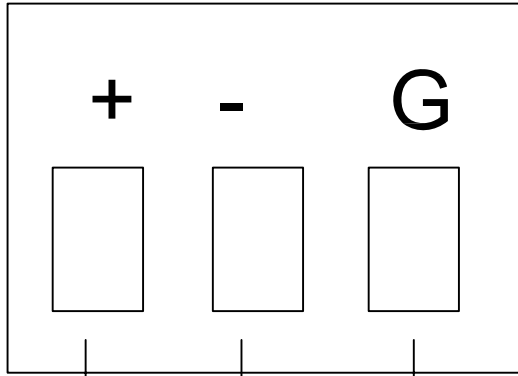

1 Amp Max. power draw
on initial power-up

24 VDC

SIGNAL BOARD

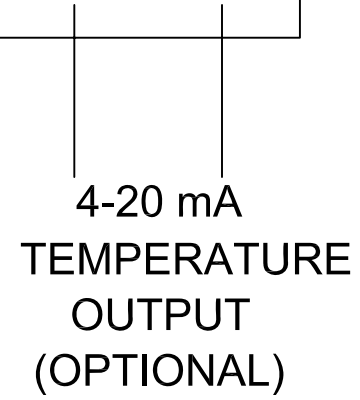
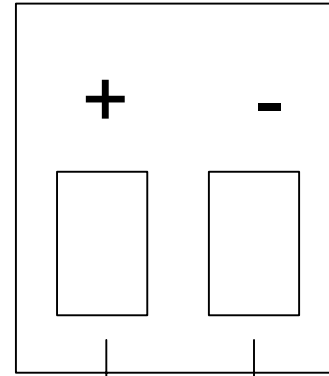
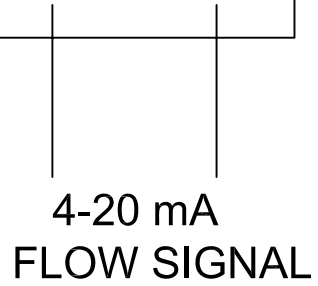
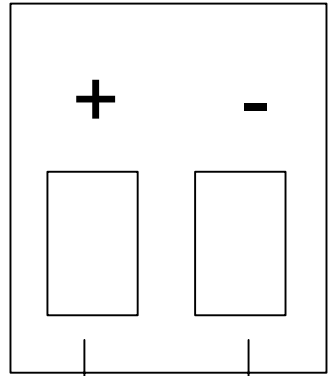

600 ohm Max Load Self Powerd

SERIAL NO.	 Thermal Instrument Company 217 Sterner Mill Road • Trevose, PA 19053, USA		
	DWG NO.:	DESCRIPTION: INTEGRAL 9500 24 VDC WIRING DIAGRAM	
ORIGINATION DATE:		DRAWN BY:	APPROVED BY:
<small>Thermal Instrument Co. Proprietary Statement: This drawing is the property of Thermal Instrument Company. Unauthorized use of this document is prohibited and subject to prosecution if violated.</small>		SCALE:	PAGE:

REV	DESCRIPTION	DATE	DRN. BY	ECN #
A	RELEASE TO PRODUCTION	4-28-02	<i>ALM</i>	

ELECTRICAL CONDULET

3/4" NPTF

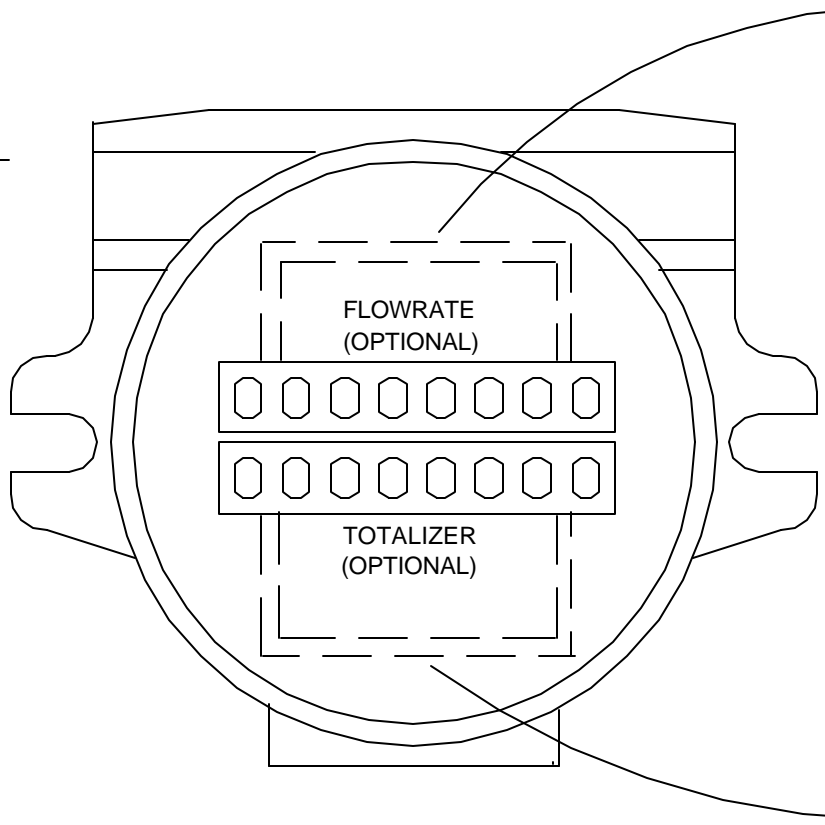

Power Board

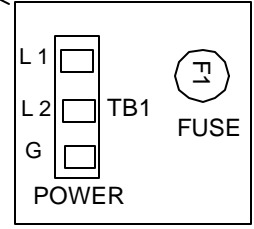

Signal Board

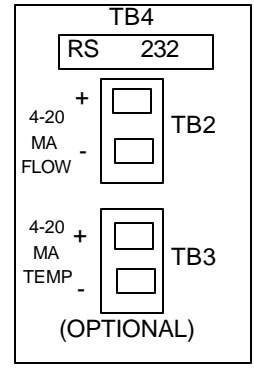

VAC WIRING DIAGRAM

SERIAL NO.

Thermal Instrument Co. Proprietary Statement
This drawing is the property of Thermal Instrument Company. Unauthorized use of this document is prohibited and subject to prosecution if violated.



Thermal Instrument Company

217 Sterner Mill Road • Trevoze, PA 19053, USA

DWG NO.:	DESCRIPTION: INTEGRAL 9500 VAC WIRING DIAGRAM	
ORINATION DATE:	DRAWN BY:	APPROVED BY:
SCALE:	MATERIAL:	PAGE:

12.

TERMINAL BOARDS

POWER BOARD

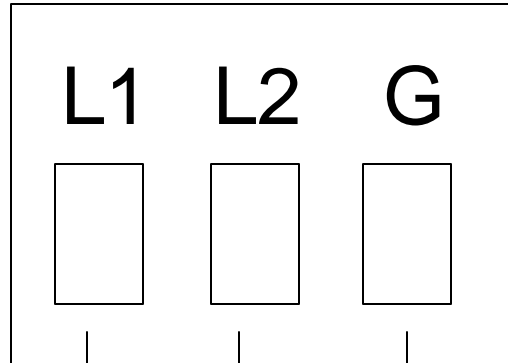

VAC
POWER

GROUND

SIGNAL BOARD

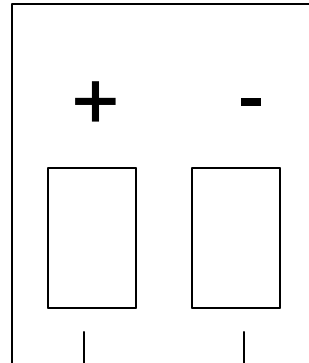

4-20 mA
FLOW SIGNAL

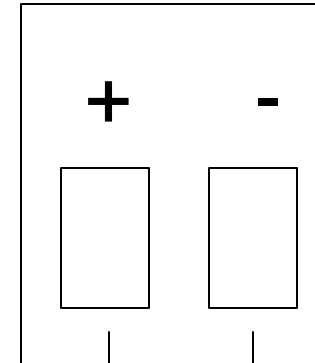

4-20 mA
TEMPERATURE
OUTPUT
(OPTIONAL)

600 ohm Max Load Self Powerd

REV	DESCRIPTION	DATE	DRN. BY	ECN #
A	RELEASE TO PRODUCTION	4-28-02	<i>RLM</i>	

VAC WIRING DIAGRAM

SERIAL NO.	 Thermal Instrument Company 217 Sterner Mill Road • Trevoze, PA 19053, USA		
	DWG NO.:	DESCRIPTION: INTEGRAL 9500 VAC WIRING DIAGRAM	
ORIGINATION DATE:		DRAWN BY:	APPROVED BY:
<small>Thermal Instrument Co. Proprietary Statement This drawing is the property of Thermal Instrument Company. Unauthorized use of this document is prohibited and subject to prosecution if violated.</small>		SCALE:	MATERIAL:
			PAGE:

13

THERMAL INSTRUMENT COMPANY

217 STERNER MILL ROAD, TREVOSE, PA 19053 U.S.A.

PHONE: 215 355-8400

FAX: 215 355-1789

Webiste: www.thermalinstrument.com

Email: office@thermalinstrument.com

GENERAL PRECAUTIONS TO BE OBSERVED IN INSTALLING FLOWMETER WIRING

When the Thermal Flowmeter or Probe is supplied with an explosion-proof conduit, it must be installed with approved wiring techniques. This calls for seals where the external wiring enters these conduits.

In the case where we have a large conduit on a Probe with multiple connections, we will have a fitting with as large as a 1 2" pipe connection. If the contractor is reducing this to 2" fittings, he must be sure that these reducers are sealed with a suitable electrical or Teflon tape. In like manner, the connectors he uses must be of the sealed conduit type.

Water entering the system from either the power wiring or the interconnecting cable system is very serious and can do damage to the metering system.

The explosion-proof type conduits are designed for that purpose only; they are not waterproof and if the system is submerged, water will enter. In applications where there is undue exposure, it may be well to go to auxiliary covering or sealing mechanisms. This may merely mean a plastic coating, a plastic bag, or in extreme cases a housing.

The same rules apply also where the external wiring enters the electronic housings. These can be either the explosion-proof type, or the NEMA 4 type. In either case adequate attention must be paid to sealing the electrical incoming lines. The cover on the NEMA 4 case is gasketed in a very adequate manner. However, in many cases the atmospheric and liquid leaks are at the point of entry of the external wiring or through the conduit from the external wiring itself.

In cases where the NEMA 4 units are used in very hazardous atmospheres or corrosive, it is advisable to purge the system to prevent corrosive attack on the electronics.

**GENERAL PRECAUTIONS TO BE OBSERVED
IN INSTALLING FLOWMETER WIRING**
(continued)

The sketch below shows how commercial seals are installed.

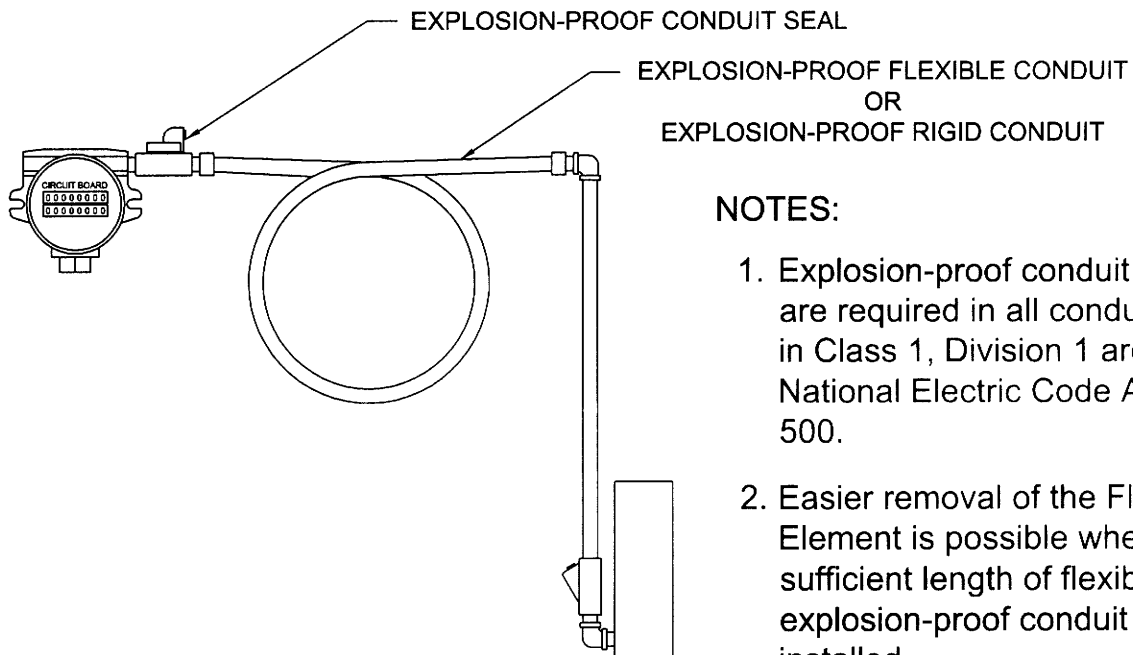

NOTES:

1. Explosion-proof conduit seals are required in all conduit runs in Class 1, Division 1 areas per National Electric Code Article 500.
2. Easier removal of the Flow Element is possible when a sufficient length of flexible explosion-proof conduit is installed.



ENY
(For Vertical or Horizontal Conduit)

ENY with Nipple



EYS
(For Vertical or Horizontal Conduit)

EYS with Nipple



EY
(For Vertical Conduit)

EY with Nipple



EYD
(Drain/Seal for Vertical Conduit)

EYD with Nipple



ENY-2
(Fixture Hanger)
(See Page L146)

Class I, Div. 1 & 2, Groups A[Ⓟ], B[Ⓟ], C, D
Class I, Zone 1, Groups IIC[Ⓟ], IIB, IIA
Class II, Div. 1 & 2, Groups E, F, G
Class III

FEATURES-SPECIFICATIONS

Application & Installation

Class I, Divisions 1 and 2

The purpose of seals in a Class I hazardous location is to minimize the passage of gases and vapors and prevent the passage of flames from one electrical installation to another through the conduit system. Seals are required to be installed within 18 inches on any conduit run entering an enclosure which contains devices that may produce arcs, sparks, or high temperature. Where two enclosures are connected by a run of conduit not over 3 ft. long, a single seal located at the center of the run is considered satisfactory. Only explosionproof unions, couplings, elbows, and conduit bodies similar to "L", "T", and "X" type shall be permitted between the sealing fitting and the enclosure.

Seals shall be located within 18 inches of the enclosure or fitting on each conduit run of 2 inch size or larger entering an enclosure or fitting that contains terminals, splices, or taps.

Each run of conduit from a hazardous location to a nonhazardous location should be sealed to minimize the amount of gases and vapors communicated beyond the seal.

Class II, Divisions 1 and 2

Where a raceway provides communication between an enclosure which is required to be dust-ignitionproof and one which is not, suitable means shall be provided to prevent the entrance of dust into the dust-ignitionproof enclosure through the raceway.

Considerations for selection seals:

Select the proper sealing fitting for the hazardous gas/vapor involved; i.e., Class I Groups A, B, C, or D.

Zone 1, Groups IIC, IIB, IIC

Select a sealing fitting for the proper use in respect to mounting position. This is particularly critical when the conduit runs between hazardous and nonhazardous areas. Some seals are designed to be mounted in any position; others are restricted to vertical mounting.

Drains

Where there is a probability that liquid or other condensed vapor may be trapped within enclosures for control equipment or at any point in the raceway system, approved means — such as installation of drain seals — shall be provided to prevent moisture accumulation.

For more complete data or special applications, consult the code or your local inspector.

Sealing compounds shall be approved for the purpose and shall not be affected by the surrounding atmosphere or liquids, and shall not have a melting point of less than 93°C. (200°F.).

In the complete seal, the minimum thickness of the sealing compound shall not be less than the trade size of the conduit, and in no case less than 5/8 inch.

Note: The amount of Killark sealing compound and packing fiber required for any seal is determined by volume, hub size and mounting position of the seal. Refer to installation data table on page F47 for specific amounts required.

Splices and taps shall not be made in fittings intended only for sealing with

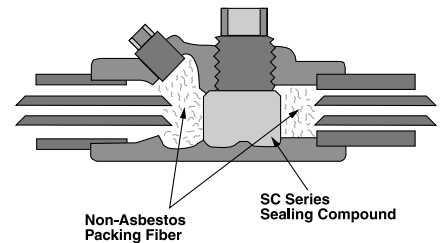

Schematic drawings illustrate the application of sealing compound, fiber dams, and installed seal with drain.

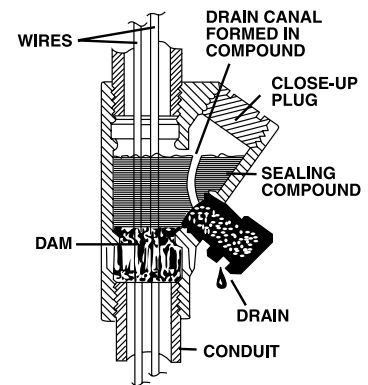

compound, nor shall other fittings in which splices or taps are made be filled with compound.

Killark sealing fittings are produced with utmost care to insure a substantial margin of safety. Threads are clean, deep, and snug. When properly installed with Killark sealing compound (SC Type) and Killark non-asbestos fiber (PF Type) for the dams, you can be sure your installation will provide more than adequate safety.

①ENY 1, 2, & 3 Series is suitable for Class I, Zone 1, Groups A, B, C, & D; EYS, EY, & EYD Series are suitable for Class I, Groups C & D.

②ENY 1, 2, & 3 Series is suitable for Class I, Zone 1, Groups IIC, IIB, IIA; EYS, EY/EYD Series and suitable for Class I, Zone 1 Groups IIB, IIC.





ENY
ENY with Nipple
(For Vertical or Horizontal Conduit)



EYS
EYS with Nipple
(For Vertical or Horizontal Conduit)

ENY-1, 2, 3
Class I, Div. 1 & 2, Groups A,B,C,D
Class I, Zone 1, Groups IIC, IIB, IIA
Class II, Div. 1 & 2, Groups E,F,G
Class III

ENY-4, 5 & 6 & EYS Series
Class I, Div. 1 & 2, Groups C,D
Class I, Zone 1, Groups IIB, IIA
Class II, Div. 1 & 2, Groups E,F,G
Class III

Listed File No. E10514
 Certified File No. LR11716

FEATURES-SPECIFICATIONS

Material/Finish

Copper-free Aluminum
(less than 4/10 of 1%)

- Electrostatically applied powder coating

Duraloy Iron

- Tri-Coat Finish of electrozinc, chromate sealant, and electrostatically applied powder coating

ENY SEALING FITTINGS						ENY WITH NIPPLE	
HUB SIZE	CATALOG NUMBER		DIMENSIONS		TURNING RADIUS	CATALOG NUMBER	
	KILLARK ALUMINUM	DURALOY IRON	A	B		KILLARK ALUMINUM	DURALOY IRON
1/2"	ENY-1 ^①	ENY-1M ^①	3-15/16"(100)	1-13/16"(46)	1-3/16"(30)	ENY-1-T ^①	ENY-1-TM ^①
3/4"	ENY-2 ^①	ENY-2M ^①	4-1/16"(103)	2-1/16"(52)	1-9/32"(33)	ENY-2-T ^①	ENY-2-TM ^①
1"	ENY-3 ^①	ENY-3M ^①	4-25/32"(121)	2-11/32"(60)	1-13/32"(36)	ENY-3-T ^①	ENY-3-TM ^①
1-1/4"	ENY-4	ENY-4M	5-3/8"(137)	3"(76)	1-25/32"(45)	ENY-4-T	ENY-4-TM
1-1/2"	ENY-5	ENY-5M	5-11/16"(144)	3-1/4"(83)	1-29/32"(48)	ENY-5-T	ENY-5-TM
2"	ENY-6	ENY-6M	6-3/8"(162)	3-15/16"(100)	2-5/16"(59)	ENY-6-T	ENY-6-TM

EYS SEALING FITTINGS						EYS WITH NIPPLE	
HUB SIZE	CATALOG NUMBER		DIMENSIONS		TURNING RADIUS	CATALOG NUMBER	
	KILLARK ALUMINUM	DURALOY IRON	A	B		KILLARK ALUMINUM	DURALOY IRON
1/2"	EYS-1 ^①	—	3-15/16"(100)	1-13/16"(46)	1-3/16"(30)	EYS-1-T ^①	EYS-1-TM ^①
3/4"	EYS-2 ^①	—	4-1/16"(103)	2-1/16"(52)	1-9/32"(33)	EYS-2-T ^①	EYS-2-TM ^①
1"	EYS-3 ^①	—	4-25/32"(121)	2-11/32"(60)	1-13/32"(36)	EYS-3-T ^①	EYS-3-TM ^①
1-1/4"	EYS-4	—	5-3/8"(137)	3"(76)	1-25/32"(45)	EYS-4-T	EYS-4-TM
1-1/2"	EYS-5	—	5-11/16"(144)	3-1/4"(83)	1-29/32"(48)	EYS-5-T	EYS-5-TM
2"	EYS-6	—	6-3/8"(162)	3-15/16"(100)	2-5/16"(59)	EYS-6-T	EYS-6-TM
2-1/2"	EYS-7	EYS-7M	7-5/8"(194)	4-1/2"(114)	4-1/8"(105)	EYS-7-T	EYS-7-TM
3"	EYS-8	EYS-8M	7-5/8"(194)	4-1/2"(114)	4-3/8"(111)	EYS-8-T	EYS-8-TM
3-1/2"	EYS-9 ^②	EYS-9M ^②	7-1/8"(181)	5-3/16"(132)	4-3/4"(121)	EYS-9-T ^②	EYS-9-TM ^②
4"	EYS-0 ^②	EYS-0M ^②	7-1/8"(181)	5-3/16"(132)	4-3/4"(121)	EYS-0-T ^②	EYS-0-TM ^②

Dimensions

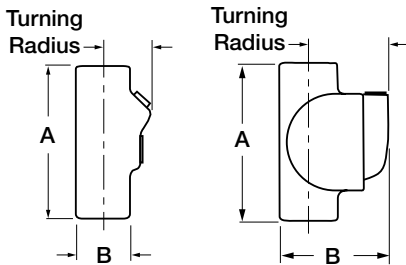

ENY Series

EYS Series

^① ENY 1, 2, & 3 Series is suitable for Class I, Groups A, B, C, & D.

EYS, EY, & EYD Series are suitable for Class 1, Groups C & D.

^② CSA Certified for Class I, Group D only.



EY **EY with Nipple**
(For Vertical Conduit)



EYD **EYD with Nipple**
(Drain/Seal for vertical conduit)

EY & EYD Series
Class I, Div. 1 & 2, Groups C,D
Class I, Zone 1, Groups IIB, IIA
Class II, Div. 1 & 2, Groups E,F,G
Class III



Listed File No. E10514



Certified File No. LR11716

FEATURES-SPECIFICATIONS

Material/Finish

Copper-free Aluminum
(less than 4/10 of 1%)

- Electrostatically applied powder coating

Duraloy Iron

- Tri-Coat Finish of electrozinc, chromate sealant, and electrostatically applied powder coating

Dimensions

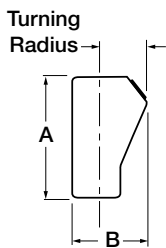

EY Series

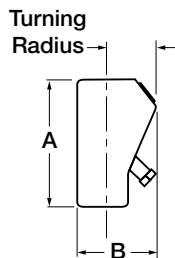

EYD Series

EY SEALING FITTINGS						EY WITH NIPPLE	
HUB SIZE	CATALOG NUMBER		DIMENSIONS		TURNING RADIUS	CATALOG NUMBER	
	KILLARK ALUMINUM	DURALOY IRON	A	B		KILLARK ALUMINUM	DURALOY IRON
1/2"	EY-1	EY-1M	3-1/16"(78)	2-1/8"(54)	2-1/4"(57)	EY-1-T	EY-1-TM
3/4"	EY-2	EY-2M	3-1/16"(78)	2-11/16"(68)	1-15/16"(49)	EY-2-T	EY-2-TM
1"	EY-3	EY-3M	4-9/32"(109)	3-1/8"(79)	2-1/4"(57)	EY-3-T	EY-3-TM
1-1/4"	EY-4	EY-4M	5-1/8"(130)	3-7/8"(98)	2-7/8"(73)	EY-4-T	EY-4-TM
1-1/2"	EY-5	EY-5M	5-1/8"(130)	4-5/8"(117)	3-7/16"(87)	EY-5-T	EY-5-TM
2"	EY-6	EY-6M	5-1/8"(230)	5-11/16"(144)	4-1/4"(108)	EY-6-T	EY-6-TM
2-1/2"	EY-7	EY-7M	7"(178)	6-5/16"(160)	4-5/8"(117)	EY-7-T	EY-7-TM
3"	EY-8	EY-8M	7"(178)	6-5/16"(160)	4-5/8"(117)	EY-8-T	EY-8-TM
3-1/2"	EY-9①	EY-9M①	8-3/4"(222)	7-1/8"(181)	5-3/8"(138)	EY-9-T①	EY-9-TM①
4"	EY-0①	EY-0M①	8-3/4"(222)	7-1/8"(181)	5-3/8"(138)	EY-0-T①	EY-0-TM①

EYD SEALING FITTINGS						EYD WITH NIPPLE	
HUB SIZE	CATALOG NUMBER		DIMENSIONS		TURNING RADIUS	CATALOG NUMBER	
	KILLARK ALUMINUM	DURALOY IRON	A	B		KILLARK ALUMINUM	DURALOY IRON
1/2"	EYD-1	EYD-1M	4-9/32"(109)	3-1/8"(79)	2-1/4"(57)	EYD-1-T	EYD-1-TM
3/4"	EYD-2	EYD-2M	4-9/32"(109)	3-1/8"(79)	2-1/4"(57)	EYD-2-T	EYD-2-TM
1"	EYD-3	EYD-3M	4-9/32"(109)	3-1/8"(79)	2-1/4"(57)	EYD-3-T	EYD-3-TM
1-1/4"	EYD-4	EYD-4M	5-1/8"(130)	3-7/8"(98)	2-7/8"(73)	EYD-4-T	EYD-4-TM
1-1/2"	EYD-5	EYD-5M	5-1/8"(130)	4-5/8"(117)	3-7/16"(87)	EYD-5-T	EYD-5-TM
2"	EYD-6	EYD-6M	5-1/8"(130)	5-11/16"(144)	4-1/4"(108)	EYD-6-T	EYD-6-TM
2-1/2"	EYD-7	EYD-7M	7"(178)	6-5/16"(160)	4-5/8"(117)	EYD-7-T	EYD-7-TM
3"	EYD-8	EYD-8M	7"(178)	6-5/16"(160)	4-5/8"(117)	EYD-8-T	EYD-8-TM
3-1/2"	EYD-9①	EYD-9M①	8-3/4"(122)	7-1/8"(181)	5-3/8"(137)	EYD-9-T①	EYD-9-TM①
4"	EYD-0①	EYD-0M①	8-3/4"(122)	7-1/8"(181)	5-3/8"(137)	EYD-0-T①	EYD-0-TM①

① CSA Certified for Class I, Group D only.





Sealing Compound



Packing Fiber



Thread Lubricants

FEATURES-SPECIFICATIONS

**Series SC/PF/LUBG
Sealing Materials**

Sealing Compound

SC Series Sealing compound is a cement used extensively for sealing conduit to prevent the spread of explosive gases. It is non-shrinking and a secure seal is formed. SC Series resists acids, water, oil, etc. It is UL Listed for use with Killark ENY, EY, and EYS Series. Also CSA certified for use with any CSA certified sealing fitting.

Packing Fiber

Killark's Packing Fiber is made from an environmentally safe, non-asbestos material. It is easy to use and forms a positive dam to hold compound (Killark SC Type) in ENY, EY, and EYS Series fittings.

Thread Lubricants

Two special blends of lubricants have been developed by Killark for use with threaded joints. These lubricants are to be used to prevent galling of pipe threads when threaded into a coupling, junction box, etc. They insure a quick release of undamaged male and female threads when parts are disassembled.

LUBG is a general purpose lubricant to be used in temperatures ranging from 0° to 125°F.

LUBT is a high-quality lubricant to be used in temperatures ranging from -40° to +500°F. It is recommended to be used on hazardous location lighting fixtures.

OUNCES REQUIRED PER FITTING				
HUB SIZE	SEALING COMPOUND			PACKING FIBER
	ENY ^①	EYS ^①	EY/EYD	
1/2"	1.5 oz.	3.0 oz.	1.0 oz.	1/16 oz.
3/4"	2.0 oz.	3.0 oz.	2.0 oz.	1/8 oz.
1"	3.0 oz.	8.0 oz.	4.5 oz.	1/4 oz.
1-1/4"	6.5 oz.	8.5 oz.	7.5 oz.	1/2 oz.
1 1/2"	8.5 oz.	17.5 oz.	12.0 oz.	1 oz.
2"	15.0 oz.	27.0 oz.	24.0 oz.	2 oz.
2-1/2"	—	42.0 oz.	44.0 oz.	3 oz.
3"	—	47.0 oz.	44.0 oz.	4 oz.
3-1/2"	—	56.0 oz.	75.0 oz.	6 oz.
4"	—	56.0 oz.	75.0 oz.	9 oz.

^① ENY/EYS suitable for both horizontal or vertical applications.

SEALING COMPOUND	
CATALOG NUMBER	SIZE PACKAGE
SC-4 OZ	4 oz.
SC-8 OZ	8 oz.
SC-1 LB	1 lb.
SC-5 LB	5 lbs.

PACKING FIBER	
CATALOG NUMBER	SIZE PACKAGE
PF-2	2 oz.
PF-4	4 oz.
PF-16	1 lb.

THREAD LUBRICANTS	
CATALOG NUMBER	CONTAINER PACKAGE
LUBT-2	2 oz.
LUBG-6	6 oz.



Explosionproof and Dust-Tight Fittings and Accessories

EXPLOSIONPROOF AND DUST-TIGHT SEALING FITTINGS CLASS I, GROUPS B*, C & D; CLASS II, GROUPS E, F & G; NEMA 7 & NEMA 9



XYB-XYBM

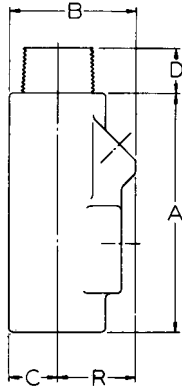

Sealing Fittings are required in Hazardous Locations and are used to isolate arc-producing devices in conduit and wiring systems, and to prevent the passage of explosive pressures from one area to another.

FOR HORIZONTAL AND VERTICAL MOUNTING - Type XYB and XYBM are suitable for either horizontal or vertical mounting and are provided with threaded plugged openings into which fiber and cement can be placed to form effective seal. XYB has female ends for conduit entrance. The XYBM has female ends with a removable threaded nipple.

*1/2", 3/4", 1" sizes Class I, Group B, C, D, Class II, E, F, G.

1 1/4", 1 1/2", 2", 2 1/2", 3", 3 1/2", 4" sizes Class I, Group C, D
Class II, E, F, G

CSA Certified LR27991

UL Listed E10493

10A4

Catalog No. Description	Conduit Size (In.)	Ounces Req. For Each Sealing Fitting		Standard Package	
		Cement	Fiber	Qty.	Tot. Wt. Lbs.
Female-Female					
XYB-2	1/2	1	1/8	5	2.1
XYB-3	3/4	2	1/4	5	2.6
XYB-4	1	3	1/4	5	3.7
XYB-5	1-1/4	6	3/8	2	2.5
XYB-6	1-1/2	9	1/2	2	3.2
XYB-8	2	18	3/4	2	5.6
XYB-10	2-1/2	23	1-1/2	2	6.2
XYB-12	3	48	3-1/8	1	6.0
XYB-14	3-1/2	70	4-1/2	1	6.8
XYB-16	4	90	6	1	8.3

Catalog No. Description	Conduit Size (In.)	Ounces Req. For Each Sealing Fitting		Standard Package	
		Cement	Fiber	Qty.	Tot. Wt. Lbs.
Male-Female					
XYBM-2	1/2	1	1/8	5	2.2
XYBM-3	3/4	2	1/4	5	2.7
XYBM-4	1	3	1/4	5	3.8
XYBM-5	1-1/4	6	3/8	2	2.6
XYBM-6	1-1/2	9	1/2	2	3.4
XYBM-8	2	18	3/4	2	5.9
XYBM-10	2-1/2	23	1-1/2	2	6.8
XYBM-12	3	48	3-1/8	1	6.3
XYBM-14	3-1/2	70	4-1/2	1	7.3
XYBM-16	4	90	6	1	8.8

Nominal Dimensions (Inches)					
Conduit Size	A	B	C	(XYBM Series Only)	Turn Radius R
				D	
1/2	3-19/32	1-13/16	5/8	11/16	1-3/16
3/4	3-25/32	2-1/16	3/4	15/16	1-5/16
1	4-3/8	2-5/16	7/8	15/16	1-7/16
1-1/4	5-5/32	2-13/16	1-1/16	1-1/16	1-3/4
1-1/2	5-11/16	3-3/16	1-3/16	1-3/16	2
2	6-13/16	3-7/8	1-1/2	1-7/16	2-3/8
2-1/2	7-1/2	4-1/2	1-7/8	1-5/8	2-11/16
3	9-9/16	5-1/2	2-3/16	1-7/8	3-5/16
3-1/2	9-1/2	6-1/16	2-3/8	2	3-11/16
4	9-9/16	6-1/2	2-5/8	2-1/8	3-7/8

Compliances

- NEC Class I, Groups B, C, D - Class II, Groups E, F, G
- UL Standard 886 - CSA Standard C22.2 No. 30

Explosionproof and Dust-Tight Fittings and Accessories

EXPLOSIONPROOF AND DUST-TIGHT SEALING FITTINGS CLASS I, GROUP D; CLASS II, GROUPS E, F & G; NEMA 7 & NEMA 9



XY 2-3-4



XYM 2-3-4



XY 5-6



XYM 5-6



XYC



XYCM



XYCS



XYCSM

Adalet Sealing Fittings are used to isolate arc-producing devices from wiring systems and to prevent the spread of explosive gases.

FOR VERTICAL MOUNTING

Types XY and XYM Fittings are for vertical mounting, and are provided with threaded plugged openings into which the sealing cement is poured. Sizes 1-1/4" x 1-1/2" have large plugged openings in the lower hub to facilitate packing fiber around the wires to form a dam. Type XYM's have removable threaded nipples. The two hubs are tapped simultaneously to assure alignment of the conduits, especially important to equipment manufacturers using short runs of conduit.

FOR HORIZONTAL & VERTICAL MOUNTING

Type XYC Fittings are for horizontal mounting only, with the cover opening in an upright position. XYCS fittings are for vertical or horizontal mounting, with removable threaded covers which can be turned to the desired position for pouring in the sealing cement. The covers are interchangeable. The male-to-female types have removable threaded nipple.

Catalog Number		Conduit Size (In.)	Ounces Required per Fitting		Standard Package	
Female/Female	Male/Female		Sealing Cement	Packing Fibre	Qty	Weight Lbs.
XY2	XYM2	1/2	1	1/8	25	10
XY3	XYM3	3/4	1	1/4	25	10
XY4	XYM4	1	2	1/4	25	12-1/2
XY5	XYM5	1-1/4	4	3/8	10	7-1/2
XY6	XYM6	1-1/2	5	1/2	10	10
XYC2	XYC2M	1/2	2	1/8	25	13
XYC3	XYC3M	3/4	2	1/4	25	13
XYC4	XYC4M	1	4-1/2	1/4	25	15
XYC5	XYC5M	1-1/4	8-1/2	3/8	10	10
XYC6	XYC6M	1-1/2	11-1/2	1/2	10	11
XYC8	XYC8M	2	13-1/2	3/4	10	12
XYC10	XYC10M	2-1/2	15	1-1/2	1	2
XYC12	XYC12M	3	31-1/2	3-1/8	1	3
XYC14	XYC14M	3-1/2	42-1/2	4-1/2	1	4
XYC16	XYC16M	4	51	6	1	5
XYC2S	XYC2SM	1/2	2	1/8	25	13
XYC3S	XYC3SM	3/4	2	1/4	25	13
XYC4S	XYC4SM	1	3	1/4	25	15
XYC5S	XYC5SM	1-1/4	6-1/2	3/8	10	10
XYC6S	XYC6SM	1-1/2	10	1/2	10	11
XYC8S	XYC8SM	2	12-1/2	3/4	10	12
XYC10S	XYC10SM	2-1/2	13-1/2	1-1/2	1	2
XYC12S	XYC12SM	3	29-1/2	3-1/8	1	3
XYC14S	XYC14SM	3-1/2	40	4-1/2	1	4
XYC16S	XYC16SM	4	48-1/2	6	1	5

CSA Certified LR27991

UL Listed E10493

Compliances

- NEC Class I, Group D Class II, Groups E, F, G
- UL Standard 886 - CSA Standard C22.2 No. 30

THE METER SHOULD BE INSTALLED IN A STRAIGHT LINE. THIS STRAIGHT LINE SHOULD HAVE A MINIMUM LENGTH OF 10 PIPE OR TUBE DIAMETERS AHEAD OF THE METER AND 5 AFTER THE METER.

ELECTRICAL CONDULET

ELECTRICAL CONDULET

"L" - DIMENSION (HEIGHT OF CONNECTION)
SUPPLIED BY CUSTOMER

PACKING GLAND

POSITION PROBE SO
ARROW GOES WITH
FLOW DIRECTION

PROBE CAN BE INSTALLED AT ANY ANGLE THROUGH THE PIPE LINE, FROM 0 DEG. TO 180 DEG. (FACTORY SHOULD BE INFORMED OF WHICH ORIENTATION, AT TIME OF ORDER)

180 DEG. 0 DEG.

INSERTION LENGTH

RECOMMENDED INSERTION LENGTHS

FOR LINE SIZES 1 1/2" TO 2":
GENTLY INSERT TO BOTTOM OF LINE THEN WITHDRAW 1/8",

FOR LINE SIZES 2 1/2" TO 7":
GENTLY INSERT TO BOTTOM OF LINE THEN WITHDRAW 1/4",

FOR LINE SIZES EQUAL TO OR GREATER THAN 8", INSERT HALFWAY INTO LINE THEN INSERT 3" MORE.

PACKING GLAND:
MATERIAL: STAINLESS STEEL
INSERT: TEFLON
THREADS: 3/4" MNPT

PROBE DIAMETER: 1/2" O.D. / 3/4" O.D. / 1" O.D. / 1 1/2" O.D.

PROBE MATERIAL: 316 S.S.

MODEL: 62-9

PROBE INSTALLATION

THERMAL INSTRUMENT CO.
TREVOSE, PA.

DATE: 4/3/13
DRAWING NO.
PROBE RECOMMENDED INSERTION LENGTH 4-2-13

EIH Instrument Enclosures

Cl. I, Div. 1 & 2, Groups B†,C,D
 Cl. II, Div. 1, Groups E,F,G
 Cl. II, Div. 2, Groups F,G
 Cl. III
 NEMA 3,4,7B†CD,9EFG

Explosionproof
 Dust-Ignitionproof
 Raintight
 Wet Locations
 Watertight

4A

Application:

- EIH instrument enclosures are used:
- to enclose instrumentation and control devices such as two-wire transmitters, flow measurement devices, temperature controls, level detectors, pressure switches, etc.
 - as an outlet box for pulling and splicing conductors
 - in hazardous, abusive and wet locations
 - to provide access to conductors for maintenance and future system changes

Features:

- 3/4" offset through feed hubs offer maximum interior space and greater working area
- 2" and 4" deep covers, solid or with glass lens
- Internal mounting pads for instrument mounting
- Internal ground screw for safe, continuous grounding
- Neoprene gasket provides a watertight seal for NEMA/EEMAC 4 and UL/CSA Type 4 applications.
- Wrenching lugs permit easy cover removal and tightening.
- Internal cover threads provide additional space inside body.
- External boss is suitable for drilling and tapping an additional conduit entry.

Standard Materials:

- Body and cover – copper-free aluminum
- Glass lens – heat tempered glass
- Gasket – neoprene

Standard Finishes:

- Corro-free™ epoxy powder coat (gray)



EIH21



EIH22

Hub Size*	Description	Cat. #
3/4	Body with 2" standard cover	EIH20
3/4	Body with 2" glass lens cover	EIH21
3/4	Body with 4" dome cover	EIH22
3/4	Body with 4" glass lens dome cover	EIH23

Options:

	Suffix to be Added to Cat. #
Cast mounting feet	MF
Natural finish	Consult Cooper Crouse-Hinds
Additional drilled and tapped opening in external boss:	
1/2"	-1
3/4"	-2

Certifications and Compliances:

- NEC/CEC:
 - Class I, Division 1 & 2, Groups B†,C,D
 - Class II, Division 1, Groups E,F,G
 - Class II, Division 2, Groups F,G
 - Class III
- NEMA/EEMAC: 3,4,7BCD,9EFG
- UL Standard: 1203
- CSA Standard: C22.2 No. 30
- FM Classification No.: 3615
- ATEX Certificate EX-95.D, 3327 U

Dimensions

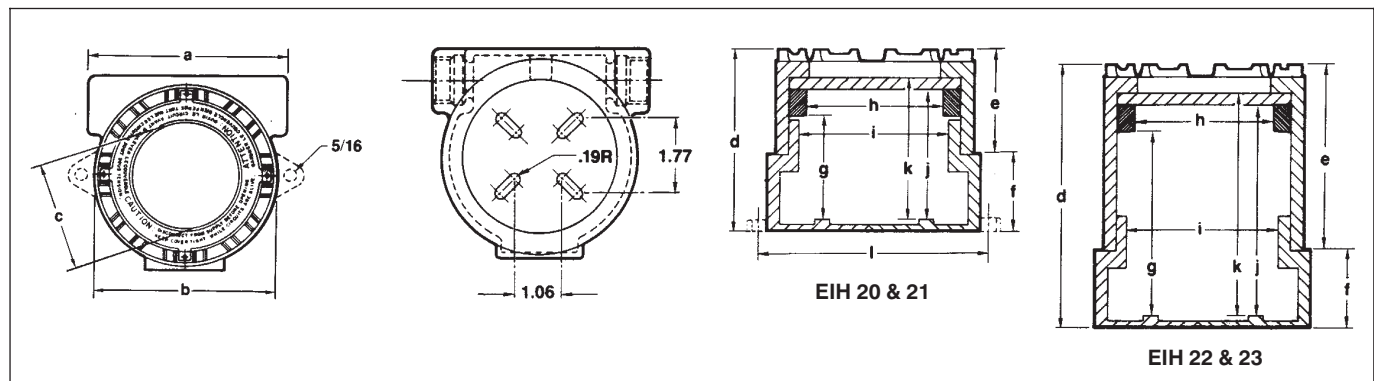

	a	b	c	d	e	f	g	h	i	j	k	l
EIH20	5.00	4.25	—	4.54	2.60	1.94	—	—	3.62	—	3.34	5.25
EIH21	5.00	4.25	2.60	4.54	2.60	1.94	2.75	2.73	3.62	3.10	—	5.25
EIH22	5.00	4.25	—	6.54	4.60	1.94	—	—	3.62	—	5.34	5.25
EIH23	5.00	4.25	2.60	6.54	4.60	1.94	4.68	2.73	3.62	5.03	—	5.25

* For 1/2" hub size, use RE21-SA.
 Dimensions are approximate, not for construction purposes.
 † For Group B applications, seal within 1 1/2" of enclosure in accordance with Sections 501-5 of the National Electrical Code* as well as any other applicable codes.



EIH/EIHT Instrument Enclosure Installation & Maintenance Information

IF 1179

SAVE THESE INSTRUCTIONS FOR FUTURE REFERENCE

APPLICATION

EIH and EIHT Instrument Enclosures are designed to house instrumentation and control equipment as well as act as a conduit outlet body in hazardous, abusive and wet locations.

The EIH and EIHT enclosure is approved by Underwriters Laboratories Inc., Canadian Standards Association, Factory Mutual and CENELEC for use in Class I, Groups B*, C† & D, Class II, Groups E, F & G and Class III hazardous (classified)

locations as defined by the National Electrical Code® and Canadian Electrical Code. It is also NEMA/UL/CSA Type 4 and IP66 rated for watertight applications.

* With conduit seals installed within 18 inches of enclosure. †For CSA group C applications, unsealed conduit lengths must not exceed 5 ft (152 cm).

INSTALLATION

WARNING

If a heat producing instrument or device is mounted in the enclosure do not install in any classified location where the operating temperature of the enclosure exceeds the ignition temperature of the hazard present.

WARNING

Electrical power must be "OFF" before and during installation and maintenance.

1. EIH Instrument Enclosures are furnished with 3/4" NPT offset throughfeed cast hubs for conduit entries. EIHT Instrument Enclosures are supplied with 3/4" NPT offset throughfeed cast hubs on the power side and one 3/4" NPT hub on the instrument side for conduit entries. (Use Crouse-Hinds RE21-SA to reduce to 1/2" hubs.)
2. Secure the enclosure to the conduit system. If the enclosure has mounting feet, select a mounting location that will provide sufficient strength and rigidity to support the enclosure as well as the enclosed device and wiring.

DIMENSIONS

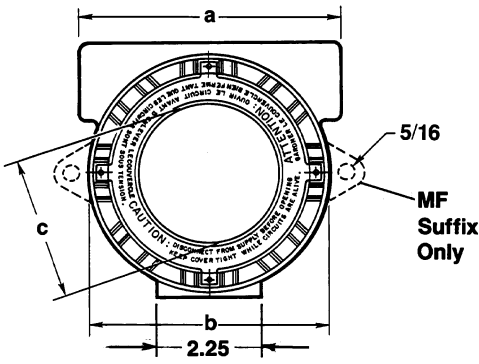

EIH 20 and 21

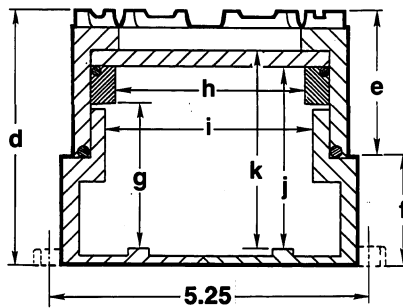

EIH 20 and 21

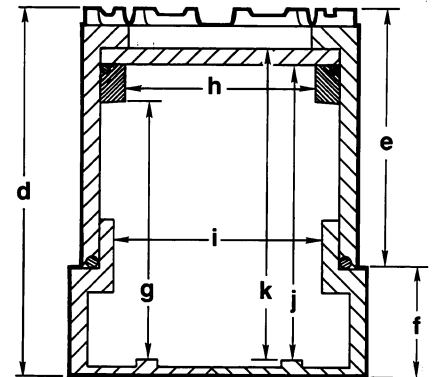

EIH 22 and 23

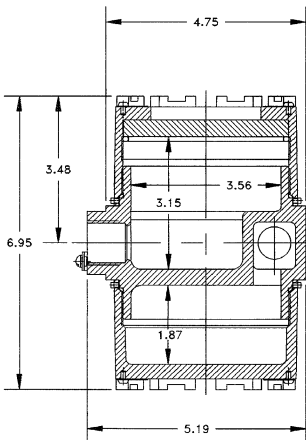

EIHT 200 and EIHT 210

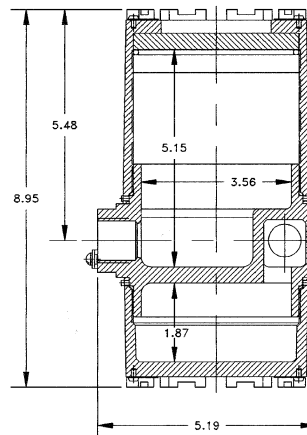

EIHT 220 and EIHT 230

Type	a	b	c	d	e	f	g	h	i	j	k
EIH20	5.00	4.50	-	4.51	2.60	1.91	-	-	3.62	-	3.47
EIH21	5.00	4.50	2.60	4.51	2.60	1.91	2.45	2.73	3.62	3.09	3.50
EIH22	5.00	4.50	-	6.51	4.60	1.91	-	-	3.62	-	5.47
EIH23	5.00	4.50	2.60	6.51	4.60	1.91	4.45	2.73	3.62	5.09	5.50

INSTALLATION continued

CAUTION

- Select a mounting location so that the enclosure will not be subjected to impact by heavy objects. Impacts can damage enclosed devices or glass lens.
- The hazardous location information specifying class and group listing of each instrument enclosure is marked on the nameplate of each enclosure.
- All unused conduit openings must be plugged. Plug unused conduit openings with Crouse-Hinds PLG2. Plugs must be a minimum of 1/8" thick and engage a minimum of 5 full threads.

3. Install Crouse-Hinds EYS Sealing Fittings required by Section 501-5 and/or 502-5 of the National Electrical Code® and Section 18 of the Canadian Electrical Code as well as any other applicable local codes and when enclosure is installed in Class I Group B hazardous locations. (For CSA Group C applications, unsealed conduit lengths must not exceed 5 ft. or 152 cm).
4. Unthread instrument (and power side) covers and carefully set aside to prevent damage to the cover threads and glass lens (when glass lens cover is used).
5. Pull wires into enclosure making certain they are long enough to make the required connections and to remove

the instrument or power supply if servicing is required. Install instrument and a power supply, if applicable and make all electrical connections. (If installing an EIHT and connections need to be made between the two halves of the EIHT enclosure see DRILLING BETWEEN ENCLOSURE WALL section of instruction sheet.)

NOTE: When installing device be sure to check instrument dimensions to avoid interference with clamping ring on glass lens units and the cover on standard units.

6. Test wiring for correctness by checking continuity and also check for unwanted grounds with insulator resistance tester. Make sure test equipment being used will not damage instrument to be housed in the EIH or EIHT instrument enclosure.
7. Carefully rethread cover to enclosure housing. Tighten cover until cover flange contacts body face.

CAUTION

Use care to prevent dirt, grit or other foreign material from lodging on threads. If any such material settles on these threads, clean them with Kerosene or Stoddard solvent*, then relubricate with Crouse-Hinds Type STL thread lubricant.

*To avoid the possibility of an explosion, oxidation and corrosion, do not use gasoline or similar solvent.

8. Tighten cover set screws to prevent cover from loosening under vibration.

DRILL & TAP INTERNAL MOUNTING PADS (EIH only)

1. Prepare a template or mark the position of the device mounting holes on the mounting pads in the bottom of the enclosure. See Figure 1.
2. Holes can be drilled and tapped in the mounting pads. See Figure 2.

WARNING

To maintain the explosionproof integrity of the enclosure with a screw in a tapped mounting pad hole, there must be a minimum of 1/16" of material between the drill point and the back wall. If for any reason a screw will not be threaded into the drilled hole a minimum of 1/8" of material must remain between the drill point and the back wall.

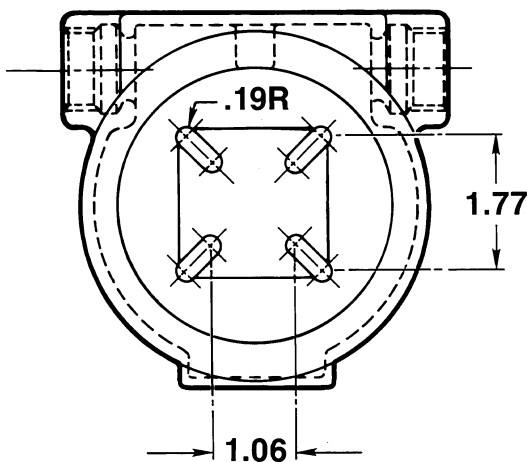

Figure 1. Internal Mounting Pad Dimensions

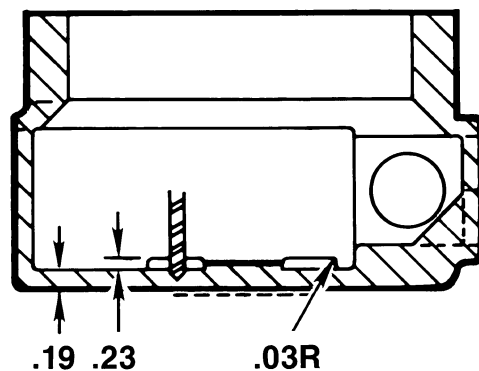

Figure 2. Mounting Pad and Back Wall Dimensions

DRILLING AND TAPPING FOR CONDUIT ENTRIES (EIH only)

The external pad has a wall thickness suitable for drilling and tapping an additional 3/4" or 1/2" conduit entry.

WARNING

The size of the pad only allows for either (1) 3/4" or (1) 1/2" NPT conduit entry. DO NOT attempt to drill and tap two conduit entries or an entry larger than 3/4".

NOTE: The conduit entrance must lie within the shaded area outlined in Figure 3.

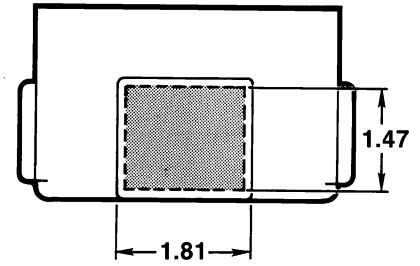
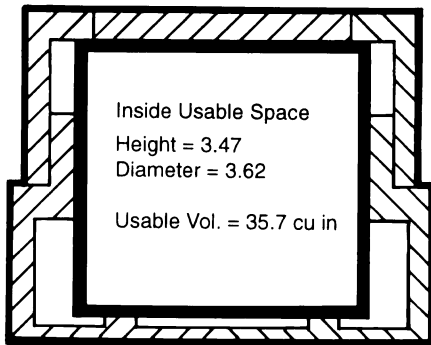
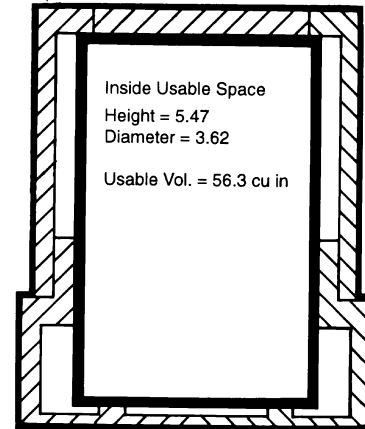

Figure 3.
Dimensions Suitable For Drilling and Tapping of External Pad.



EIH 20



EIH 22

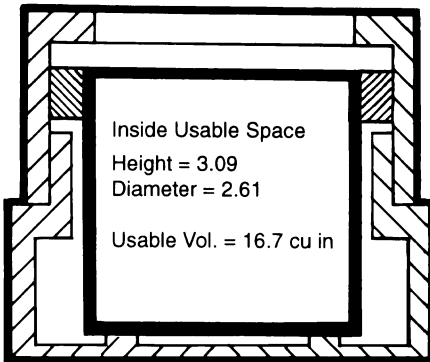

EIH 21*

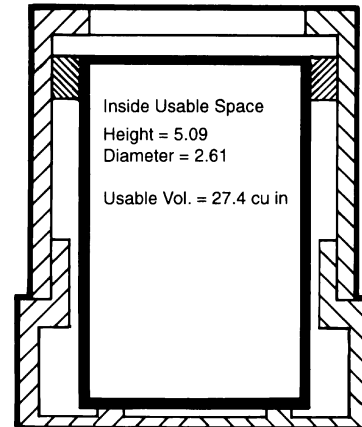

EIH 23*

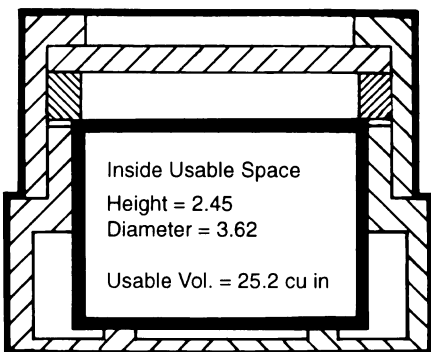

EIH 21*

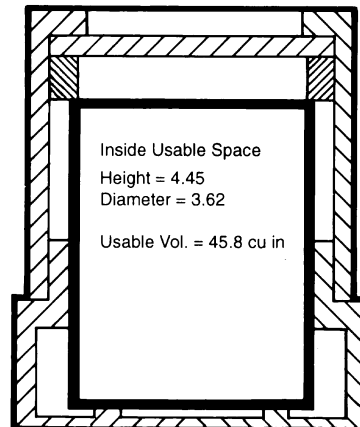

EIH 23*

Figure 4. Internal Usable Space

*For EIH21 and 23, determine usable volume based on diameter and height of the instrument to be enclosed.

DRILLING AND TAPPING FOR CONDUIT ENTRIES (EIH only) continued

Female conduit entries must be taper tapped with the thread form and taper (3/4 in. per ft.) conforming to NPT. A standard NPT male gage must enter the tapped opening 1-1/2 turns past the gage notch. The opening is tapped deeper than standard NPT gage to ensure a minimum of five full threads engagement with standard NPT threaded conduit (refer to current NEMA FB-1).

Opening may be tapped to accept listed reducers that provide an integral conduit stop or openings may be tapped and counterbored 1/16 to 1/8 inch larger than conduit O. D. to a depth that will still provide a tapped surface of sufficient length for the number of threads within the limits shown in Table 1. This will allow assembly of a conduit bushing to the end of the conduit protruding through the wall.

TABLE 1

Number of threads in a conduit opening without a conduit stop. (Minimum 5 threads, maximum 20 threads per inch.)		
Trade Size of Conduit (Inch)	Number of Threads per Inch	Maximum Number of Threads
1/2	14	7
3/4	14	7

CAUTION

Sealing fittings must be installed with access allowing the dams to be made and the sealing compound to be properly poured.

DRILLING BETWEEN ENCLOSURE WALL (EIHT only)

Up to six 1/4" holes can be drilled between the wall of the two sides of the EIHT enclosure for pass throughs. The minimum spacing between holes must be 0.187 inches.

1. Remove both threaded covers before attempting to drill holes through the EIHT wall.
2. See figure 5 for defined area for pass throughs.

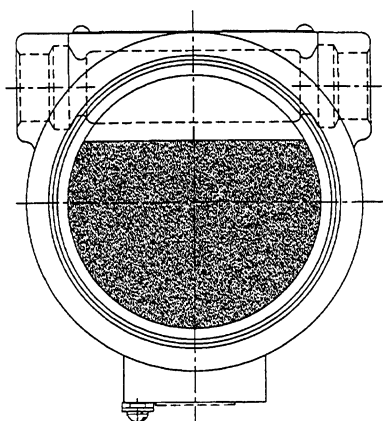

Figure 5

MAINTENANCE

WARNING

Always disconnect primary power source before opening enclosure for inspection or service.

1. Frequent inspection should be made. A schedule for maintenance checks should be determined by the environment and frequency of use. It is recommended that it should be at least once a year.
2. Perform visual, electrical and mechanical checks on all components on a regular basis.
 - Visually check for undue heating evidenced by discoloration of wires or other components, damaged or worn parts, or leakage evidenced by water or corrosion in the interior.
 - Electrically check to make sure that all connections are clean and tight and that the device is operating properly.

All statements, technical information and recommendations contained herein are based on information and tests we believe to be reliable. The accuracy or completeness thereof are not guaranteed. In accordance with Crouse-Hinds "Terms and Conditions of Sale", and since conditions of use are outside our control, the purchaser should determine the suitability of the product for his intended use and assumes all risk and liability whatsoever in connection therewith.

REV	DESCRIPTION	DATE	DRN. BY	ECN #
A	RELEASE TO PRODUCTION	4-28-02	ALM	

ELECTRICAL CONDULET

3/4" NPTF

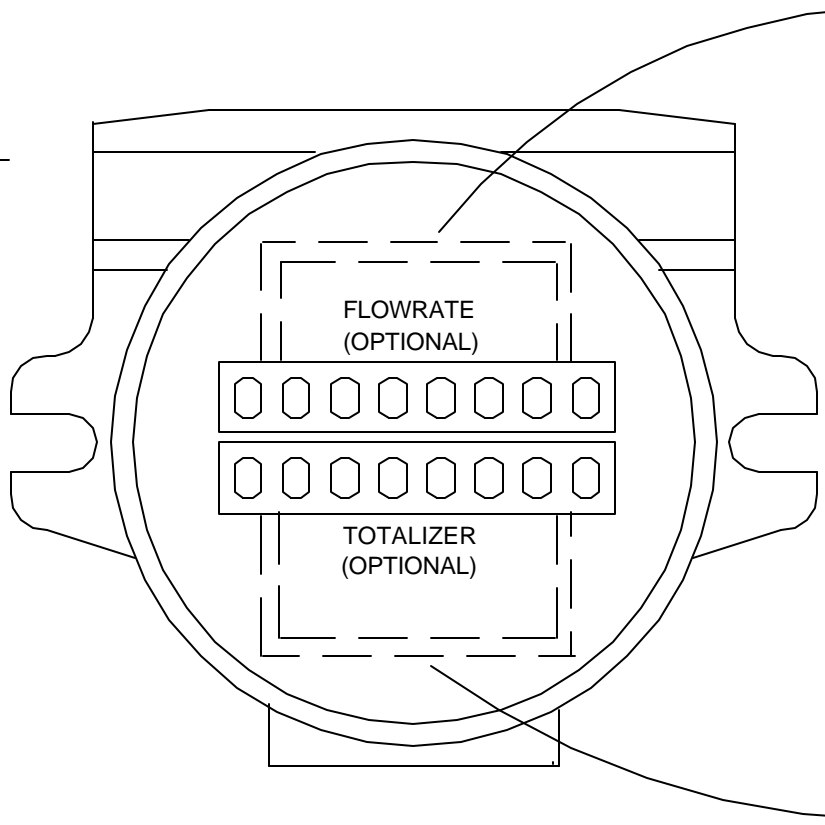

Power Board

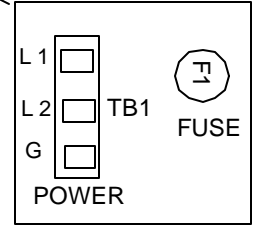

Signal Board

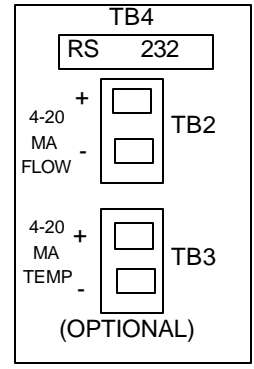

VAC WIRING DIAGRAM

SERIAL NO.

Thermal Instrument Co. Proprietary Statement
This drawing is the property of Thermal Instrument Company. Unauthorized use of this document is prohibited and subject to prosecution if violated.



Thermal Instrument Company

217 Sterner Mill Road • Trevoze, PA 19053, USA

DWG NO.:	DESCRIPTION: INTEGRAL 9500 VAC WIRING DIAGRAM	
ORIGINATION DATE:	DRAWN BY:	APPROVED BY:
SCALE:	MATERIAL:	PAGE:

28.

TERMINAL BOARDS

REV	DESCRIPTION	DATE	DRN. BY	ECN #
A	RELEASE TO PRODUCTION	4-28-02	<i>RLM</i>	

POWER BOARD

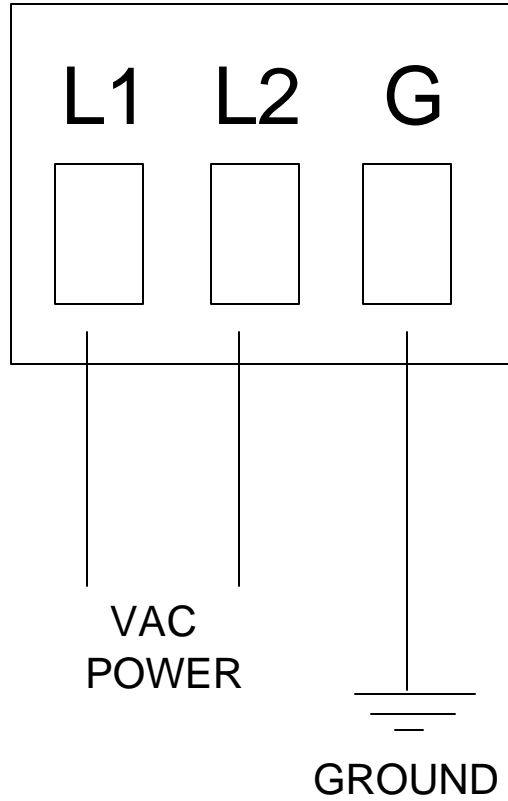

SIGNAL BOARD

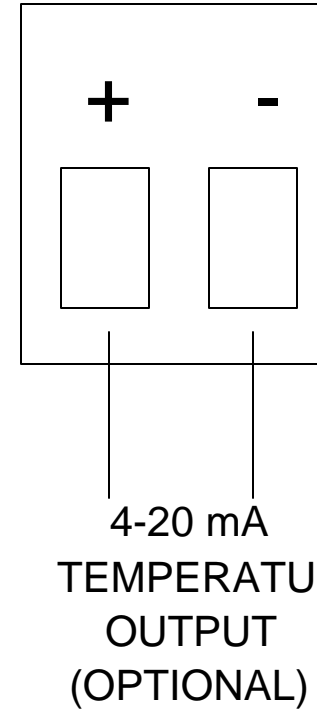
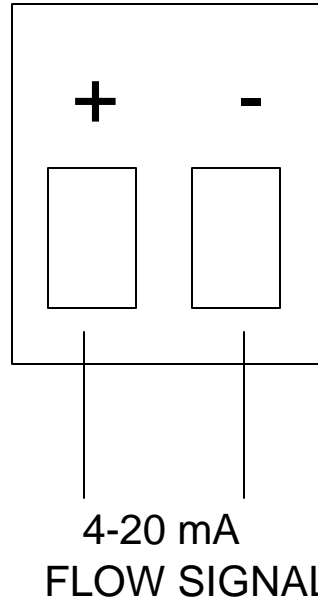

600 ohm Max Load Self Power

VAC WIRING DIAGRAM

SERIAL NO.	 Thermal Instrument Company 217 Sterner Mill Road • Trevoze, PA 19053, USA		
	DWG NO.:	DESCRIPTION: INTEGRAL 9500 VAC WIRING DIAGRAM	
ORIGINATION DATE:	DRAWN BY:	APPROVED BY:	
<small>Thermal Instrument Co. Proprietary Statement This drawing is the property of Thermal Instrument Company. Unauthorized use of this document is prohibited and subject to prosecution if violated.</small>	SCALE:	MATERIAL:	PAGE:

29.

REV	DESCRIPTION	DATE	DRN. BY	ECN #
A	RELEASE TO PRODUCTION	4-29-02	<i>RLM</i>	

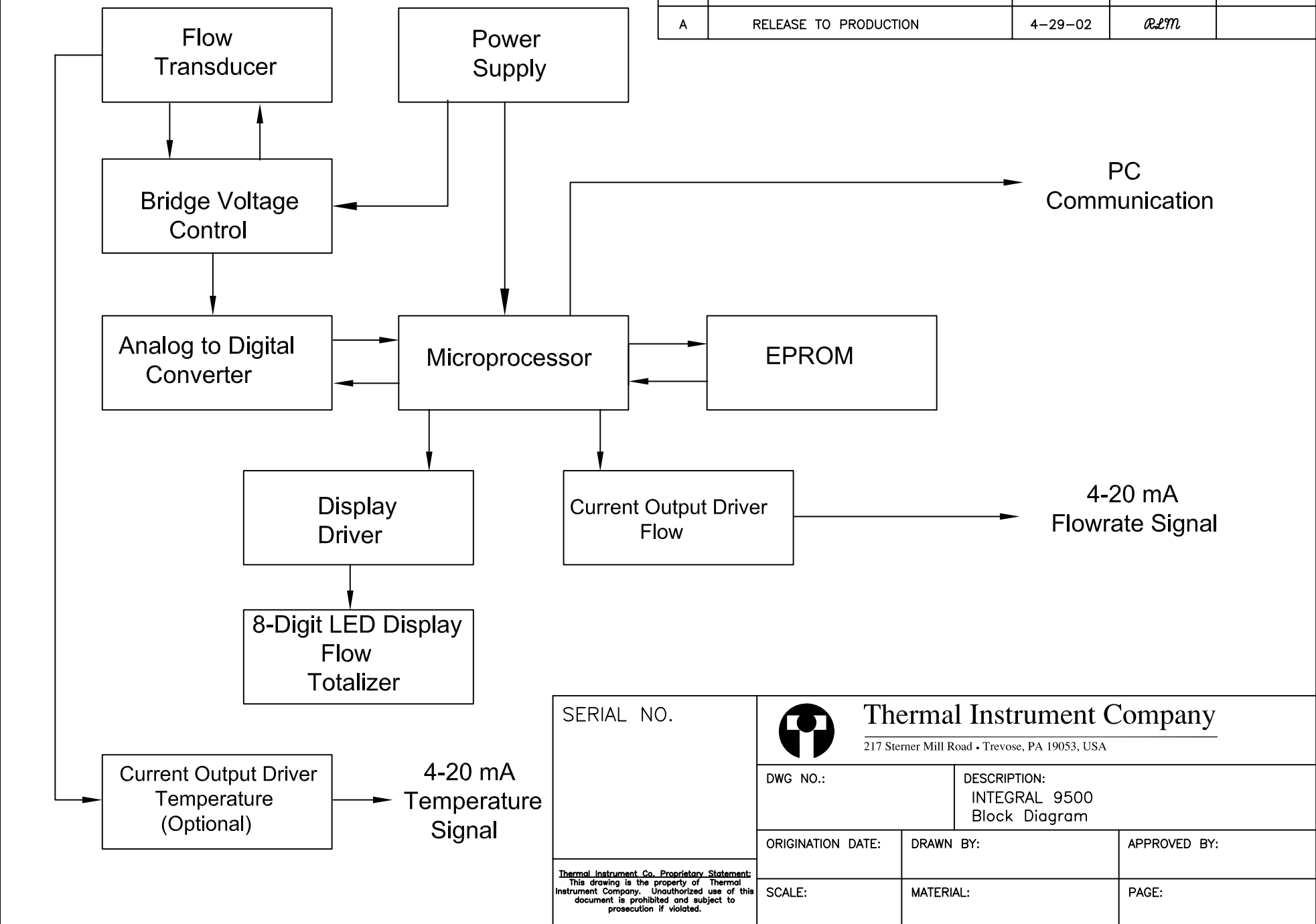

SERIAL NO.

Thermal Instrument Co. Proprietary Statement:
This drawing is the property of Thermal Instrument Company. Unauthorized use of this document is prohibited and subject to prosecution if violated.

 Thermal Instrument Company 217 Sterner Mill Road • Trevose, PA 19053, USA			
			DWG NO.:
ORIGINATION DATE:	DRAWN BY:	APPROVED BY:	
SCALE:	MATERIAL:	PAGE:	

Field Calibration Check Integral 9500P Electronics

The 9500P electronic signal conditioner output can be checked by simulating the voltage output of the Flow sensor with an external DC voltage source.

- 1 Turn off power to electronics.
- 2 Remove push-on jumper across pins 4 and 5 of TB1 (located above Zero and Span Pots).
- 3 Connect an external variable DC voltage source, Negative to Pin 2 and Positive to Pin 5 (TB1).
- 4 Apply power to the electronics.
- 5 Locate the calibration specification sheet in the instruction manual labeled "Component Values Determined at Calibration".
- 6 Turn on variable DC voltage source and set DC voltage to the 10% of full-scale flow rate transducer voltage (EXC). The display, if available, should indicate the 10% of full scale flow rate. The DC mA Output should be 5.6mA (10% of scale). If the mA output is not correct, adjust ZERO potentiometer R7 until 5.6 mA. Potentiometer R7 is adjacent to pin 1 of U3 chip.
- 7 Set the DC voltage to the 90% of full-scale flow rate transducer voltage (EXC). The display, if available should indicate the 90% of full scale flow rate. The DC mA output should be 18.4 mA. If the mA output is not correct, adjust SPAN potentiometer R11 until 18.4 mA. Potentiometer R11 is located adjacent to capacitor C1. You may have to return to step #6 if any adjustments were made due to the ZERO and SPAN potentiometers adjustments offset each other a little.
- 8 After the 10% and 90% of full-scale flow rates are checked, check 0, 20, 30, 40, 50, 60, 70, 80, and 100% points.
- 9 Turn off power to the meter.
- 10 Disconnect the DC Voltage Source
- 11 Place jumper back on across pins 4 and 5 on TB1.
- 12 Turn on power to meter
- 13 If procedure does not prove satisfactory, recheck steps taken and if necessary contact Thermal Instrument Company for assistance

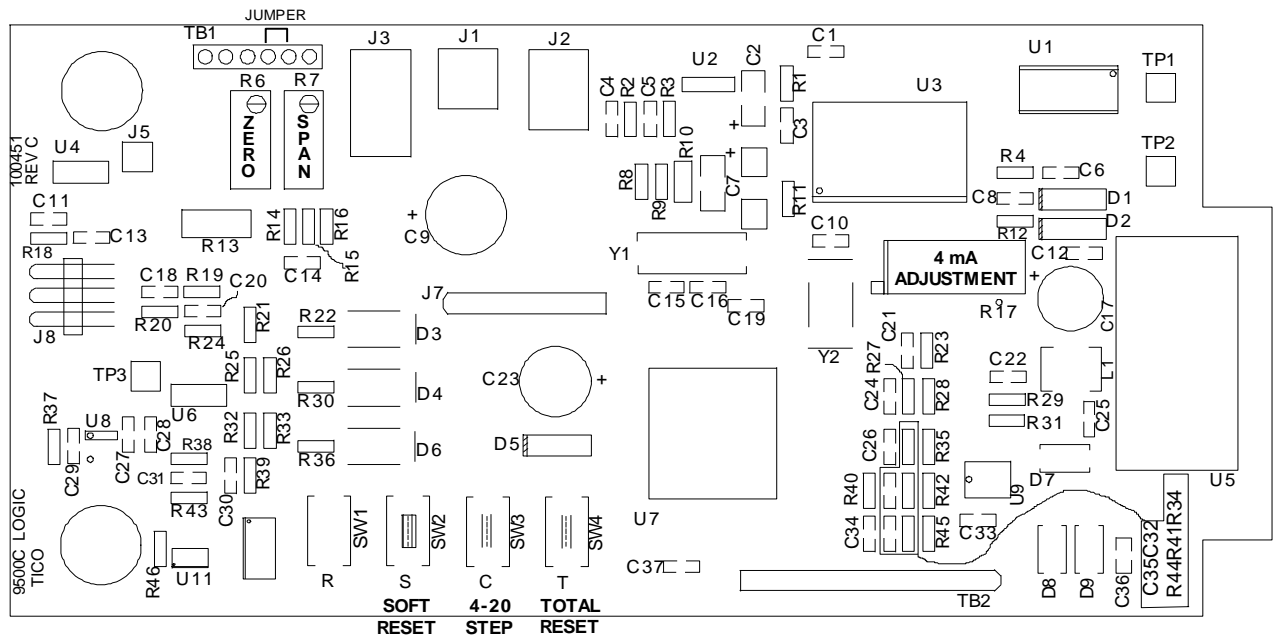

THERMAL INSTRUMENT CO.

217 Sterner Mill Road, Trevose, PA 19053

Telephone No. (215) 355-8400

FAX No. (215) 355-1789

Website: www.thermalinstrument.com

email: office@thermalinstrument.com

TROUBLESHOOTING

Troubleshooting of a malfunctioning flowmeter is a process of isolating the particular circuit area which is out of range and then finding the components causing the failure. Before looking into possible circuit problems it will be profitable in most cases to first determine that the problem is not internal to the electronics. As odd as it may sound, most apparent flowmeter malfunctions are a result of incorrect installation or changes in process operating conditions.

Typical installation problems are:

Fluid not flowing.

Flow rate for temperature out of calibration range.

Fluid not identical to calibration fluid.

(Ex: Air instead of CO₂ or Water instead of Glycol)

Fluid has coated flow element.

(Ex: Very dirty gas or liquid that leaves a film or layers)

Flow element installed too close to upstream or downstream flow disturbance.

(Minimum 10 pipe diameters upstream and 5 pipe diameters downstream)

Power not on or incorrect voltage.

(Ex: Connecting 24 VDC in place of 110 VAC)

Flow Element wiring incorrect.

Output wiring incorrect.

For Installations that had been operating correctly it is frequently helpful to review the above list since changes made to process, piping, or wiring have been know to effect flowmeter performance.

If a problem has been identified from the above list and cannot be corrected, it will be helpful to discuss the situation with Thermal Instrument Company for possible solutions (new calibration or meter modifications).

