



www.ThermalInstrument.com

**217 Sterner Mill Road
Trevose, PA 19053 U.S.A.
P: 215-355-8400
F: 215-355-1789**

Info@ThermalInstrument.com

OPERATIONS & INSTALLATION MANUAL

CUSTOMER ORDER DETAILS

CUSTOMER NAME:

CUSTOMER PO#:

SERIAL NUMBER:

MODEL DESCRIPTION:

APPLICATION SERVICE:

LINE SIZE:

POWER:

OUTPUT: 4-20 MADC

Congratulations and thank you for your purchase of a Thermal Instrument Company mass flow meter system.



MODEL 9500P FLOW TRANSMITTER WITH INSERTION OR IN-LINE STYLE FLOW TRANSDUCER

	<u>PAGE</u>
Flow Meter Selection	3
Field Wiring Diagram	4
Outline Dimensions	5
Flow Curves & Calibration Spec Sheets	6
Meter Configuration Page Introduction	7
Guidelines & Precautions	8
Installation	10
Insertion Probe Install Guide	14 - 15
Operation & Info	16
Totalizer Reset	18
Block Diagram/Power Board	19
General Precautions	20
Instrument Housing	28
Field Calibration	33
Troubleshooting	34-36
Spare Parts	37

1A.3 Wiring Diagrams

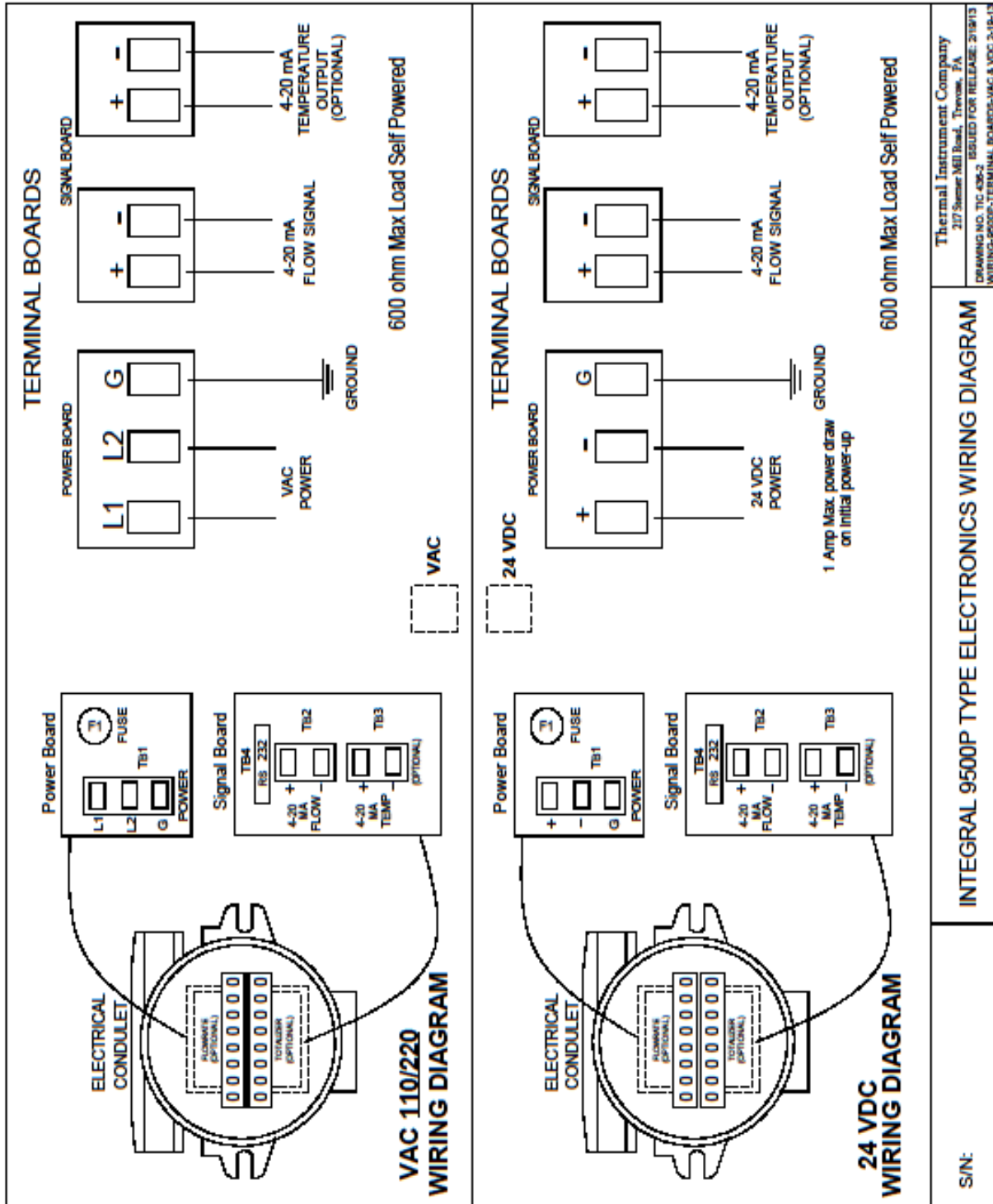

Specific Outline Dimensions

All Flow Curves & Calibration Spec Sheet

1.0 Introduction

1.1 Preface

These instructions contain all of the information that you will require for using this flow meter from Thermal Instrument Company.

These instructions are aimed at people mechanically installing the flow meter, connecting it electrically, configuring the parameters and commissioning it as well as service and maintenance engineers.

Note

It is the responsibility of the customer that the instructions and directions provided in the manual are read, understood and followed by the relevant personnel before installing this device.

1.2 Flow Meter Configuration

The Flow Meter Application Details can be confirmed on Page #3 of this manual or by reviewing the label and tags attached to each specific flow meter as shown in **Figure 1**.

Each flow meter has a specific Serial # for identification purposes. Note: When Receiving Remote Electronic Transmitters, the flow element and transmitter are a matched set.

Figure 1—Example Only



Items Inspection

1. Check for mechanical damage due to possible improper handling during shipment. All claims for damage are to be made promptly with the shipping company.
2. Make sure that the information on the product identifier plate and labels (**Figure 1** above) corresponds to the ordering information.

1.3 Further Information

The contents of these operating instructions shall not become part of or modify any prior or existing agreement such as the original quotation, or any other written communications. These operating instructions are a guidance for this flow meter and do not create new warranties or modify the existing warranty.

Product Information available on our website:

(<http://www.thermalinstrument.com>)

2.0 General Guidelines & Precautions

Receiving / Inspection

- Unpack carefully and inspect overall condition
- Check the packing list to compare what you received is all there

If the above items are fine, then move on to the next section, otherwise contact our customer support group at **(215) 355-8400** and provide us with purchase order number or serial number of the flow meter.

Factory Calibration Note

This flow meter from Thermal Instrument Company has been factory calibrated to the specifications and flow range as stipulated by the customer. There is no need to perform any verification or calibration on this device prior to mounting and start-up in the application.

Prior to Installation

Qualified electrical personnel should be installing this instrument. The installation should be done per National Electrical Code and the power to the electrical wiring should be off during the installation. Where the instructions call out for use of electrical current, the operator assumes all responsibilities for conformance to safety and practices.

Alerts

This flow meter is not designed for weld-in place applications with the exception of the UHP (Ultra High Pure) in-line flow designs. The conventional welding technique can cause damage to the Nickel or Platinum sensors from the current being passed from ground to the hot weld side.

Damage due to moisture ingress into the enclosure is not covered under the warranty of this product and proper conduit seals must be applied for all-weather conditions. This flow transmitter contains electrostatic discharge (ESD) sensitive components, so use proper ESD precautions when handling the device.

Verify Mounting Area for Insertion or In-Line Flow design to make certain that everything fits properly.

Installation Point

Make sure that there are 10 pipe diameters upstream and 5 pipe diameters down stream of the flow meter from any bends or interferences in the process piping or ductwork in order to achieve the greatest accuracy.

2.0 General Guidelines (Continued)

Mechanical Care of Enclosure

Be careful of the enclosed electronics when removing the conduit cover. After the initial installation, never open the conduit when the power is connected, especially in a classified hazardous area. Gently lift the cover from the 9500P electronic assembly and place it in a safe location where dirt cannot get inside or, if the display option has been selected, where dirt can get on the inside of the viewing window. When replacing the cover, take special care that the display legend plate is centered on the display and that the cover window lugs do not hit the legend plate in the last two or three turns of the cover.

Electrical Care of Enclosure

Proper wire size or gauge selected for all connections should be the minimum allowable by your plant standards and regulations. The enclosure has limited space available for large gauge wire and we recommend no larger than 12 gauge for power. When snaking the wires around the electronic assembly, special care should be taken of any protruding parts. The parts are capable of withstanding some abuse, but still be cautious not to force the wire through.

2.1 Installation / Mounting of Flow Meter

Verify the Dimensions of the Flow Meter against your process connection and piping.

The Thermal Instrument Company Model 62-9 insertion probe has a variety of process mounting connections, from MNPT to welded flange, The insertion probe commonly comes with an adjustable mechanical connection which can be tightened down for permanent mounting. Verify all mounting and installation variables before tightening process packing gland.

If the installation is for Thermal Instrument Company Model 600-9 in-line flow tube design, then make certain that the pipe diameters and mounting sections are verified.

Verify the Flow Direction for the Flow Meter and Proper Placement

The 62-9 insertion probe has an indexing arrow on the flat portion of the process connection located just below the base of the enclosure. On Model 600-9 it will be on flow element body. See Figure Below.



**Figure Left: Index Arrow
on 62-9 Insertion Probe**

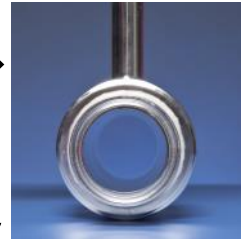

**Figure Right: 600-9
In-Line Flow Tube
(actual tube will have flow
direction arrow)**

Align the insertion probe during the installation so that the flat areas of the mechanical process connection with the arrow are parallel to the direction of the process flow, and the arrow points in the direction of the process flow.

For the 600-9 in-line flow tube assembly, the indexing arrow is etched on the flow tube, and should be pointing in the direction of the flow. If the flow device is not mounted in the proper direction, then there will be a reduction in accuracy.

Compression Fitting Mounting (62-9 Insertion Probe Style)

A. Determine the inside diameter of the process pipe at the pre-determined mounting location. If the Inner pipe diameter is 1-1/2" to 2", then the insertion probe will utilize the dual tip design and would be inserted to the bottom of the line and withdrawn up by 1/8". For line sizes 2-1/2" to 7", the probe would be inserted completely to the bottom of the line, and then withdrawn 1/4". For line sizes equal to or greater than 8", insert the probe halfway into the line, and then insert 3" further for optimal positioning.

B. Once inserted into the line at the proper positioning, tighten down the connection to ANSI B16.5 torque specifications. Make sure that proper thread sealants are applied prior to torque down of the fitting.

2.1 Installation/Mounting Continued

Compression fitting Mounting Continued

- C. Adjust the probe so that the flats of the mechanical process gland are parallel with the flow and that the indexing arrow is also in the direction of the flow path.
- D. Once the insertion length and probe positioning are correct, tighten the mechanical gland assembly using two wrenches with one on the smaller connection and the other on the larger connection. Do not over tighten by more than one and one half turn. The mechanical packing gland assembly can be readjusted if needed.

NPT Pipe Thread Mounting (62-9 Insertion Probe Only)

- A. Make certain that a proper environmental sealant is applied to the process threads of the insertion probe prior to installation and tightening into line.
- B. Make certain that the conduit is not rotated more than 180° with the insertion probe fastened to the process line as the RTD (Resistance Temperature Detector) wires could be damaged.
- C. The threads on the insertion probe are right handed and should not be over tightened or cross threaded as this can cause moisture to leak out or ingress.

Flanged Mounting (62-9 Insertion Probe Only)

- A. Make certain that the proper sized flow meter flange and ANSI rating is correct for the mating process side of the flange. Verify the line pressure vs. the overall flange rating.
- B. Make certain that a new gasket is available for the flange connection and that the area on the process flange side is cleaned and free of any raised areas that could be a leakage path for media inside the line.
- C. Prior to fastening the flanges together, make sure that the indexing arrow is parallel with the flow direction.
- D. Carefully mount the flow meter with the flange to the process side flange and use the bolts with nuts to secure the flanges together.

Installation/Mounting Continued

2.2 9500P Integral Electronics Design

The Model 9500P transmitter / electronics is available as an integral design. The integral design features the transmitter / electronics mounted atop the insertion or in-line flow style sensors.

2.3 9500P Remote Electronics Design

The Model 9500P transmitter / electronics is also available as a remote mounted design whereby the transmitter / electronics can be remotely located up to 2000 feet from the sensing element via interconnecting cable. This remote mount version then comprises the 9500P transmitter / electronics in the remote area and a junction box enclosure with a wiring terminal block mounted atop the sensing element or probe design.

2.4 Insertion Style Probes Model 62-9

For installation of the 62-9 insertion probe, the 10 upstream and 5 down stream conditions still apply. The insertion probe must be rotated so that the index arrow etched on the probe is facing towards the flow of the media.

Thermal Instrument Company has two styles for the insertion probes; one is the dual tip which is most often applied for lines smaller than 2" and the second design is the single piece machined probe, which is available in 1/2", 3/4" or 1" OD size or greater. The size of the probe is determined by the flow velocity of the media as well as the application parameters like operating pressure. In **Figure X & Y** below, we show the insertion probes for the single piece machined probe and the dual tip design.

FIGURE X

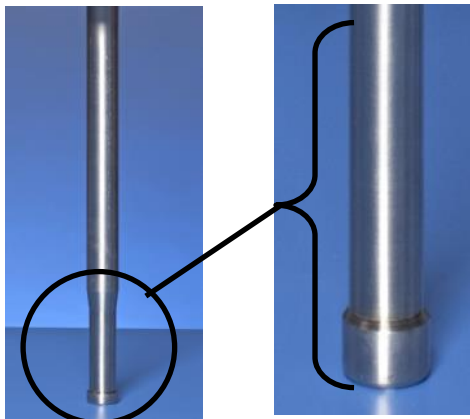

**Model 62-9 Single Piece
Machined Insertion Probe**

FIGURE Y

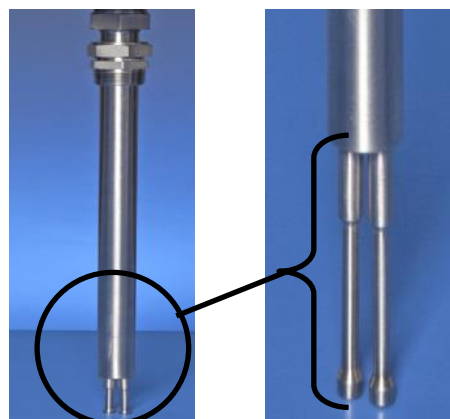

**Model 62-9DT Dual
Tip Insertion Probe**

2.5 Proper Sealing of the Transmitter / Electronics

Prior to mounting the insertion style probe into the tube or pipe line, make certain that there is a proper seal applied to the process connection. If the process connection is an NPT style, then Teflon tape or a liquid style sealant is applied. If the connection on the probe is a flange or other type of surface connection, then an appropriate gasket material should be in place between the probe connection and the pipe mounting section.

Additionally, the conduit seals on the transmitter / electronics enclosure should also be done properly so that no external moisture can penetrate the threaded area. Also, be certain to tighten down the enclosure cover for the integral / compact transmitter and / or remote junction enclosure and remote mounted transmitter / electronics. Thermal Instrument Company is not responsible for any 9500P transmitter, junction enclosure, or external equipment damage due to negligence on improper sealing of any conduits going to the enclosures or the enclosure covers not being secured with the O-ring gasket on the base of the transmitter / electronics.

Recommended Insertion Probe Installation

THE METER SHOULD BE INSTALLED IN A STRAIGHT LINE. THIS STRAIGHT LINE SHOULD HAVE A MINIMUM LENGTH OF 10 PIPE OR TUBE DIAMETERS AHEAD OF THE METER AND 5 AFTER THE METER.

RECOMMENDED INSERTION LENGTHS

FOR LINE SIZES 1 1/2" TO 2":
GENTLY INSERT TO BOTTOM OF LINE THEN WITHDRAW 1/8",

FOR LINE SIZES 2 1/2" TO 7":
GENTLY INSERT TO BOTTOM OF LINE THEN WITHDRAW 1/4",

FOR LINE SIZES EQUAL TO OR GREATER THAN 8":
INSERT HALFWAY INTO LINE THEN INSERT 3" MORE.

L - DIMENSION (HEIGHT OF CONNECTION) SUPPLIED BY CUSTOMER

PACKING GLAND:

MATERIAL: STAINLESS STEEL

INSERT: TEFLON

THREADS: 3/4" MNPT

PROBE DIAMETER: 1/2" O.D. / 3/4" O.D. / 1" O.D. / 1 1/2" O.D.

PROBE MATERIAL: 316 S.S.

MODEL: 62-9	PROBE INSTALLATION	THERMAL INSTRUMENT CO. TREVOSE, PA.
		DATE: 2/24/11 DRAWING NO. INSTALLATION-62-RECOMMENDED LENGTHS-2

THE METER SHOULD BE INSTALLED IN A STRAIGHT LINE. THIS STRAIGHT LINE SHOULD HAVE A MINIMUM LENGTH OF 10 PIPE OR TUBE DIAMETERS AHEAD OF THE METER AND 5 AFTER THE METER.

FOR ALL LINE SIZES EXCEPT 2" AND 1 1/2"

DUAL TIP PROBE INSTALLATION LENGTH

POSITION BOTTOM OF THE DUAL TIPS THROUGH THE PIPE UNTIL REACHING 1/2 THE INSIDE DIAMETER PLUS 1/2"

FOR 2" SCH 40 PIPE AND 1 1/2" SCH 40 PIPE

INSERT GENTLY UNTIL TIP TOUCHES BOTTOM THEN WITHDRAW 1/8"

INSTALLATION LENGTH

FLOW SENSOR

SERIAL NO.	<p>Thermal Instrument Company 217 Steiner Mill Road, Trevose, PA 19053, USA</p>	<p>DWG NO.: INSTALLATION LENGTH-4207-PG</p> <p>DESCRIPTION: INSTALLED DUAL TIP PROBE</p>	<p>ORIGINATION DATE: 12/2/16</p> <p>DRAWN BY: MJH</p> <p>APPROVED BY: MJH</p>
<small>Thermal Instrument Company Proprietary Information. This document is the property of Thermal Instrument Company. It is to be used only for the purposes intended and is not to be distributed, copied, or otherwise used without the express written consent of Thermal Instrument Company.</small>	SCALE: NONE	MATERIAL: AS NOTED	PAGE: 1 of 1

Recommended Insertion Probe Installation (cont.)

Recommended installation when customer process is known to have significant moisture in the pipe. Significant moisture is characterized by the presence of water droplets contacting the flow sensor.

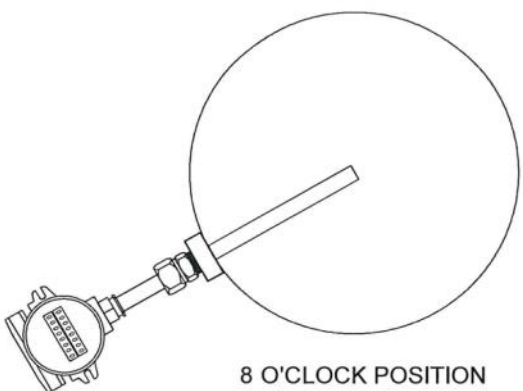

8 O'CLOCK POSITION

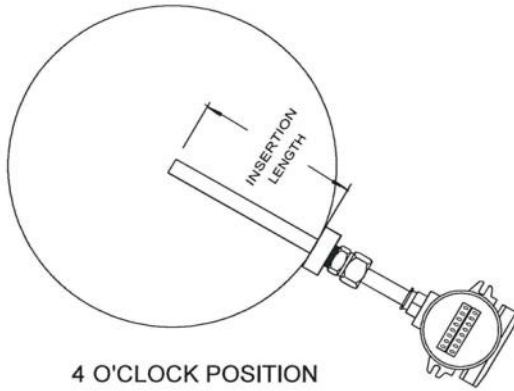

4 O'CLOCK POSITION

RECOMMENDED INSERTION LENGTHS

FOR LINE SIZES 1 1/2" TO 2":
GENTLY INSERT TO BOTTOM OF LINE THEN WITHDRAW 1/8",

FOR LINE SIZES 2 1/2" TO 7":
GENTLY INSERT TO BOTTOM OF LINE THEN WITHDRAW 1/4",

FOR LINE SIZES EQUAL TO OR GREATER THAN 8", INSERT HALFWAY INTO LINE THEN INSERT 3" MORE.

FOR HORIZONTAL FLOW

IF POSSIBLE POSITION PROBE TYPE FLOW METER TO APPROXIMATELY EITHER ANGLE.

 Thermal Instrument Company 217 Sierner Mill Road, Treviso, PA 19053, USA	
DWG NO.: INSTALLATION ORIENTATION LANDFILLS 3-12-19	DESCRIPTION: RECOMMENDED PROBE POSITION ANGLES FOR LANDFILL USE
ORIGINATION DATE: 3/12/19	DRAWN BY: M.JH APPROVED BY: M.JH
SCALE: NONE	MATERIAL: N/A PAGE: 1 of 1

3.0 Transmitter Information & Wiring

3.1 Operation

Flow Transducer

In this section, there will be references to functional block diagrams. See **Figure 2** for the main block diagram on page 17. The Thermal Instrument Company thermal mass flow meter utilizes a unique compound bridge circuit that measures and controls the temperature of the precision RTD that is bonded to the dry side of the media conduit.

The power required to maintain this temperature is proportional to the mass flow rate of the fluid or gas. This raw measured signal then goes through a linearization circuit to straighten the flow curve. Additionally, some method of temperature compensation must be performed on the signal.

Electronics Transmitter

The transmitter / electronics used with the majority of the flow transducers is the 9500P. This electronics has a series of printed circuit boards with interconnectivity. The mass flow measurement and functionality of the design is accomplished on the Bridge Voltage Control Board shown in **Figure 3** on page 17. The output signal is passed to the Logic Control Board where the non-linear signal is digitized. This digital value is used to look up the corresponding flow value in an EEPROM (Electrically Erasable Programmable Read-Only Memory). The linearized value is then used to drive an LED flow rate display, an 8-digit totalizer, and the analog 4 to 20 mA DC current flow signal.

The Logic Control Board incorporates a micro-processor, which controls the data flow and modifies the calculations according to parameters stored in EEPROM. The microprocessor also controls the communications link between the flow meter and a personal computer. This communication link is used to monitor and change the operating factors for the flow device.

3.2 Input Power and Output Signals

110/220 VAC - The electronics may be powered by either 110 VAC or 220 VAC, but the selection is made by jumpers not accessible in the field. As shown on the Field Wiring Drawing No. TIC-436-2, the HI line is connected to Terminal Block 1, point 1 at the top. The LO (neutral) line is connected to point 2 and the earth line is connected to point 3. Take special note that the two-point terminal blocks are for the output signals. **DO NOT CONNECT HIGH VOLTAGE POWER TO THESE BLOCKS.** There are protective Poly Switch breakers on the output signal lines and they will “open” up if overloaded but circuits can still be damaged.

3.0 Transmitter Information & Wiring

3.2 Input Power and Output Signals

24 VDC - (22 volts DC min, 30 volts DC max) - As shown on the Field Wiring Drawing No. TIC-436-2, (Page 4) the positive line is connected to Terminal Block 1, point 1 at the top. The negative line is connected to point 2 and the earth line (when used) is connected to point 3. Take special note that the two-point terminal blocks are for the output signals.

DO NOT CONNECT HIGH VOLTAGE POWER TO THESE BLOCKS. There are protective Poly Switch breakers on the output signal lines and they will “open” up if overloaded, but circuits can still be damaged.

The 24 volt version of the Model 9500 can be connected in a three-wire configuration (four - wire with temperature output). In this configuration the current signal common to the flowmeter is eliminated and the common line for the output signal is connected at the 24 volt source negative. If plant regulations permit, the three-wire configuration could be two wires plus shield for the common.

Output Signals

Terminals are provided for local instrument powered two-wire signals (positive and common). If the Temperature Transmitter option has been provided, a single wire common connection may be used or two-wire cables may be run. There are protective Poly Switch breakers on the output signal lines and they will “open” up if overloaded but circuits can still be damaged. When power is on if there is zero output current (there should be at least 4 mA even through a current meter) disconnect the field wiring and check the terminal block points for a voltage. Presence of a voltage (typically 20 to 30 volts) with no current flow indicates that the Poly Switch breakers have been tripped. Power must be turned off if the Poly Switch breakers are tripped in order for them to reset. They do not need to be replaced as a fuse. Maximum load resistance is 500 ohms.

Flow - The 4-20 mA flow signal is at Terminal Block 2, the positive connection on point 1 (at the top of Block 2) and the negative on point 2. The output current signal is a 4 mADC at zero flow and 20 mADC at 100% of rated flow.

Temperature (optional) - The 4-20 mA temperature signal is at Terminal Block 3, the positive connection on point 1 (at the top of Block 3) and the negative on point 2.

Totalizer Pulse Output - The 9500 pulse output's standard configuration is 12 Volt DC pulse with a 20 millisecond on time and 1 pulse per specified flow range. The three variables are, 1 - Voltage pulse or dry contact closures output, 2 - Length of pulse 20 millisecond standard can be shorter or longer. (Example: 5 millisecond, 100 millisecond, 1 second, Etc.) 3 - Pulses per unit of Flow rate, example: 1 pulse per flow unit, 10 pulses per flow unit. The three variables are not field changeable therefore Thermal Instrument needs to know what are the variables need to accommodate the equipment interface.

Start-up Operation - With all connections having been completed and tested, a short but fast flow rate should be obtained in order to clean gas bubbles and impurities from the flow tube.

CAUTION - Flow and transducer must be within 50°C (122°F) of operating temperature before power is applied. Sensors may be damaged if transducer temperature is below this limit and/or calibration may not be accurate.

Apply power and allow a 10 minute warm-up period.

3.0 Transmitter Information & Wiring

3.3 Continued Operation

Electronics Unit Field Service Details

Terminal Board

Figure 2 (Pg.17) shows the block diagram. **Figure 3** (Pg.17) shows the component configuration for the two field wiring boards. All field wiring is made to the terminal board. There are two (optionally three) terminal blocks. Connect the input power to the three-position block TB1 according to TIC-436-2 on the field wiring diagram. Terminal Block TB2 carries the 4-20 mADC flow signal and, if optionally ordered, TB3 carries the 4-20 mADC signal for the specified temperature range. Both current signals require a loop with a maximum resistance of 500 ohms. The signals are powered by the internal electronics and must not be connected to an external power supply. (NOTE: Hart & Modbus options require external power)

Flow Bridge Voltage Control Board

The flow bridge voltage control board controls the flow transducer sensor and provides the non-linear flow signal to the logic board.

In calibration, the potentiometer R2 is set to balance the temperature sensor with the flow sensor at the lowest temperature in the application range. A second pot, R11 is set to balance the bridge at the high extreme of the application temperature range. These two adjustments are determined in calibration and should NOT be changed.

Logic Board

The logic board converts the non-linear analog flow signal to a digital value, determines the linear equivalent from the data stored in an Electronically Erasable Programmable Read Only Memory (EEPROM), runs an 8-Digit totalizer and outputs the linear flow data as an analog signal (4 to 20 mADC) and a 5-1/2 digit flow rate display.

R6 is adjusted so that the voltage on TB5 pin 1 is equal to the zero flow voltage from the flow bridge. Adjustment is then made to R7 so, when the maximum voltage is applied to the S+ input, the voltage at TB5 pin 3 equals 4.096 volts. Potentiometer R17 provides the 4 mA adjustment for the output current signal.

Access to Menu System & Resetting Totalizer is done on the Logic Board

To Reset Totalizer Display to “0”. Press and hold the black push button (See Figure 3 on Page 19) labeled (SW4) in for 5 seconds until display flashes. Totalizer has been reset at this point.

See Addendum on Page 35 for additional information on the Integral Menu System.

To Reset Totalizer Display to “0”. Press and hold the black push button (See Figure 3 on Page 19) labeled (SW4) in for 5 seconds until display flashes. Totalizer has been reset at this point.

Figures for Electrical Diagrams from Previous Page

Figure 2 - Block Diagram

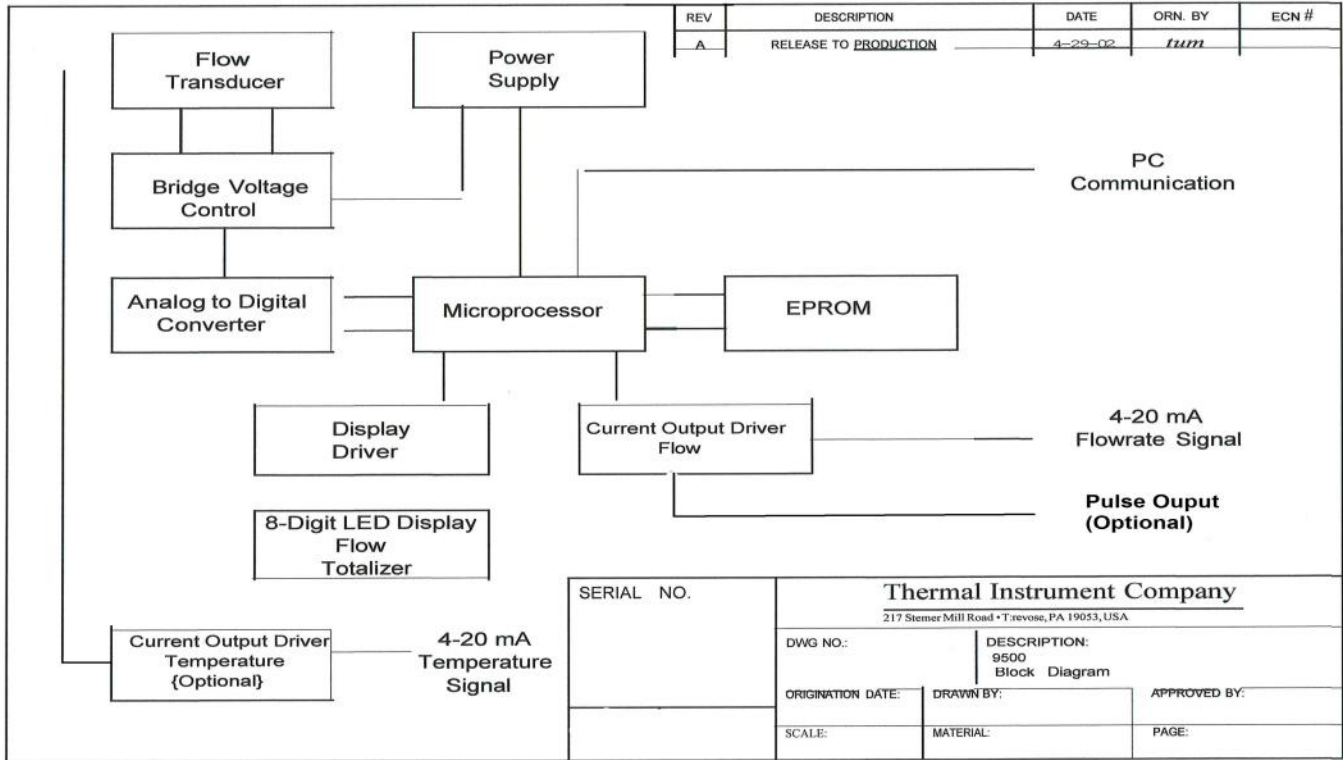
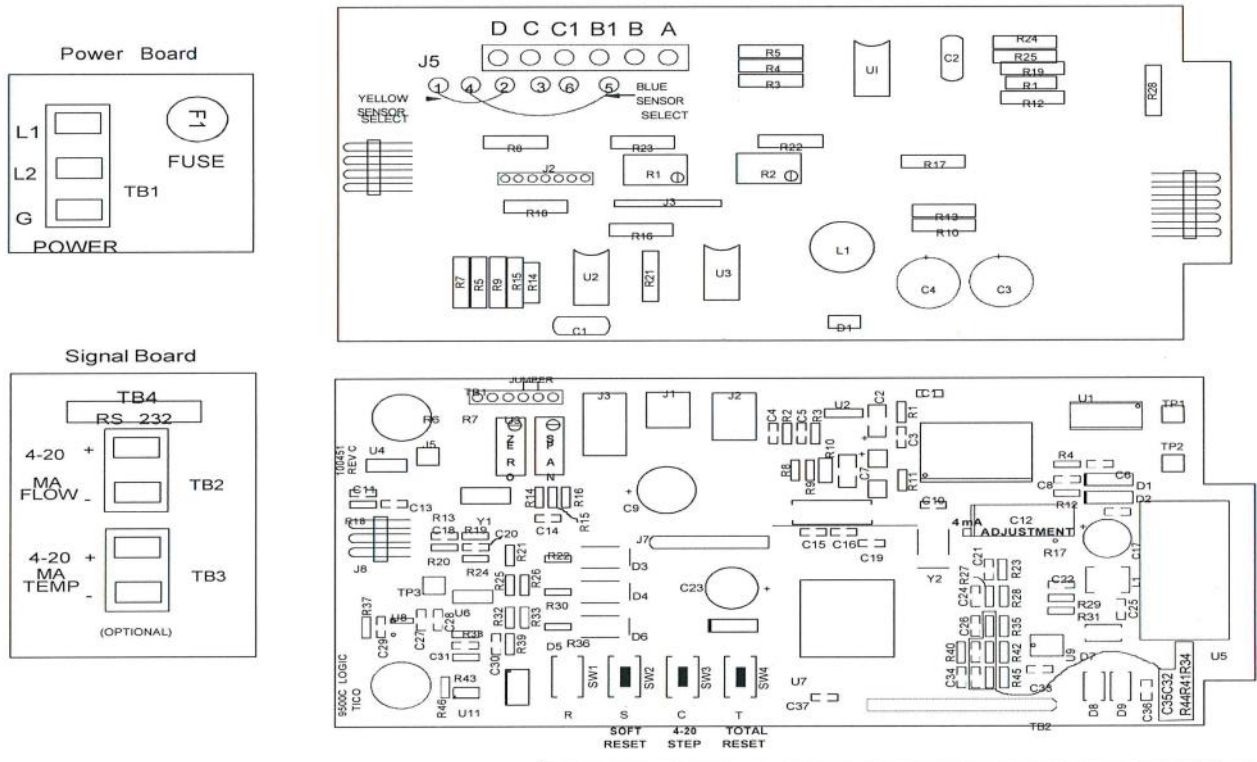

Figure 3 - Two Field Wiring Boards



General Precautions

GENERAL PRECAUTIONS TO BE OBSERVED

IN INSTALLING FLOWMETER WIRING

When the Thermal Flowmeter or Probe is supplied with an explosion-proof conduit, it must be installed with approved wiring techniques. This calls for seals where the external wiring enters these condulets.

In the case where we have a large conduit on a Probe with multiple connections, we will have a fitting with as large as a 1 2" pipe connection. If the contractor is reducing this to 2" fittings, he must be sure that these reducers are sealed with a suitable electrical or Teflon tape. In like manner, the connectors he uses must be of the sealed conduit type.

Water entering the system from either the power wiring or the interconnecting cable system is very serious and can do damage to the metering system.

The explosion-proof type condulets are designed for that purpose only; they are not waterproof and if the system is submerged, water will enter. In applications where there is undue exposure, it may be well to go to auxiliary covering or sealing mechanisms. This may merely mean a plastic coating, a plastic bag, or in extreme cases a housing.

The same rules apply also where the external wiring enters the electronic housings. These can be either the explosion-proof type, or the NEMA 4 type. In either case adequate attention must be paid to sealing the electrical incoming lines. The cover on the NEMA 4 case is gasketed in a very adequate manner. However, in many cases the atmospheric and liquid leaks are at the point of entry of the external wiring or through the conduit from the external wiring itself.

In cases where the NEMA 4 units are used in very hazardous atmospheres or corrosive, it is advisable to purge the system to prevent corrosive attack on the electronics.

General Precautions Continued

GENERAL PRECAUTIONS TO BE OBSERVED IN INSTALLING FLOWMETER WIRING (continued)

The sketch below shows how commercial seals are installed.

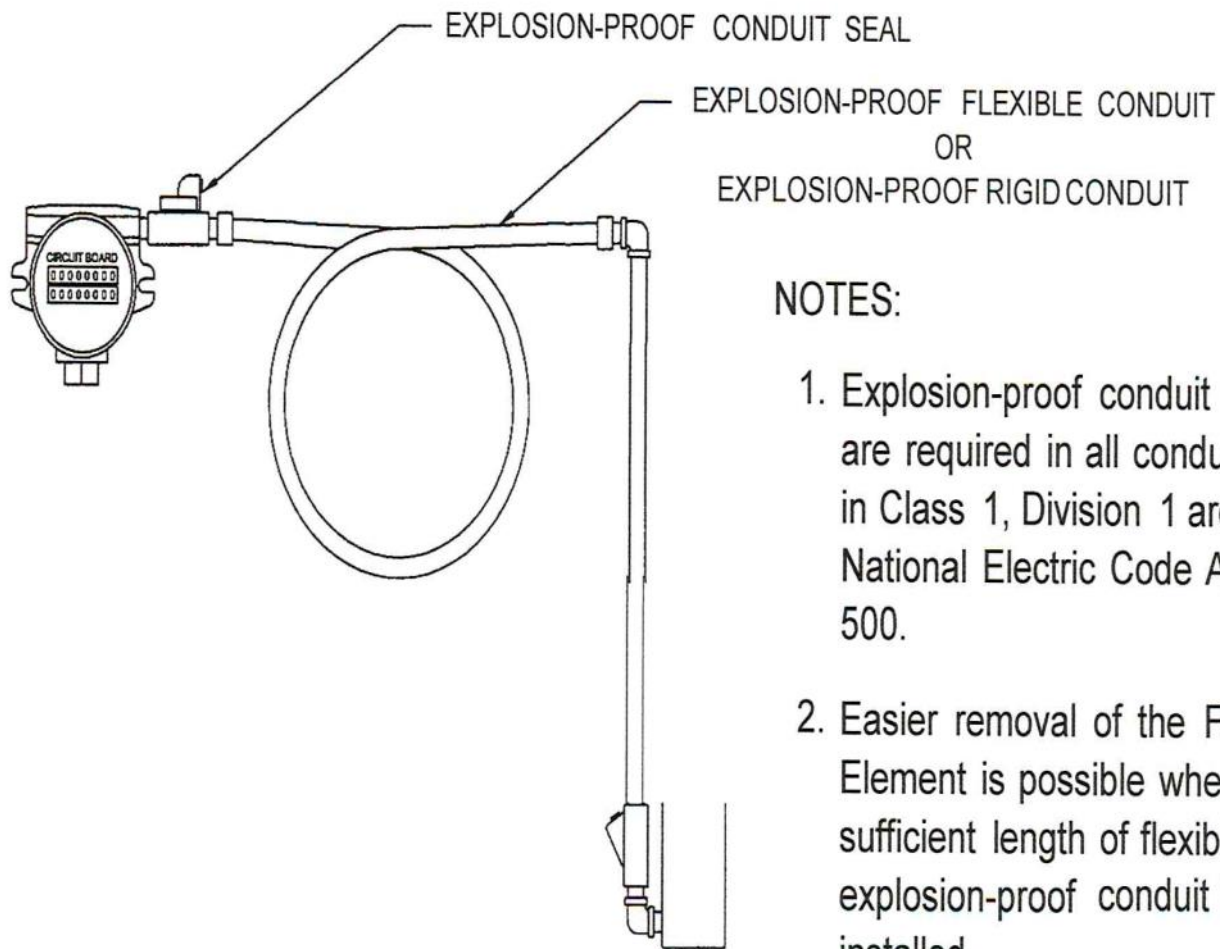

Enclosure Terminations and Seals

F44

EY SERIES • FITTINGS
SEALING FITTINGS



ENY
(For Vertical or Horizontal Conduit)



ENY with Nipple
(For Vertical or Horizontal Conduit)



EY
(For Vertical Conduit)



EY with Nipple
(For Vertical Conduit)



ENY-2
(Fixture Hanger)
(See Page L146)



EYS
(For Vertical or Horizontal Conduit)



EYS with Nipple
(For Vertical or Horizontal Conduit)



EYD
(Drain/Seal for Vertical Conduit)



EYD with Nipple
(Drain/Seal for Vertical Conduit)

Class I, Div. 1 & 2, Groups A⁽¹⁾, B⁽¹⁾, C, D
Class I, Zone 1, Groups IIC⁽¹⁾, IIB, IIA
Class II, Div. 1 & 2, Groups E, F, G
Class III

FEATURES-SPECIFICATIONS

Application & Installation

Class I, Divisions 1 and 2

The purpose of seals in a Class I hazardous location is to minimize the passage of gases and vapors and prevent the passage of flames from one electrical installation to another through the conduit system. Seals are required to be installed within 18 inches on any conduit run entering an enclosure which contains devices that may produce arcs, sparks, or high temperature. Where two enclosures are connected by a run of conduit not over 3 ft. long, a single seal located at the center of the run is considered satisfactory. Only explosionproof unions, couplings, elbows, and conduit bodies similar to "L", "T", and "X" type shall be permitted between the sealing fitting and the enclosure.

Seals shall be located within 18 inches of the enclosure or fitting on each conduit run of 2 inch size or larger entering an enclosure or fitting that contains terminals, splices, or taps.

Each run of conduit from a hazardous location to a nonhazardous location should be sealed to minimize the amount of gases and vapors communicated beyond the seal.

Class II, Divisions 1 and 2

Where a raceway provides communication between an enclosure which is required to be dust-ignitionproof and one which is not, suitable means shall be provided to prevent the entrance of dust into the dust-ignitionproof enclosure through the raceway.

Considerations for selection seals:

Select the proper sealing fitting for the hazardous gas/vapor involved; i.e., Class I Groups A, B, C, or D.

Zone 1, Groups IIC, IIB, IIC

Select a sealing fitting for the proper use in respect to mounting position. This is particularly critical when the conduit runs between hazardous and nonhazardous areas. Some seals are designed to be mounted in any position; others are restricted to vertical mounting.

Drains

Where there is a probability that liquid or other condensed vapor may be trapped within enclosures for control equipment or at any point in the raceway system, approved means — such as installation of drain seals — shall be provided to prevent moisture accumulation.

For more complete data or special applications, consult the code or your local inspector.

Sealing compounds shall be approved for the purpose and shall not be affected by the surrounding atmosphere or liquids, and shall not have a melting point of less than 93°C. (200°F.).

In the complete seal, the minimum thickness of the sealing compound shall not be less than the trade size of the conduit, and in no case less than 5/8 inch.

Note: The amount of Killark sealing compound and packing fiber required for any seal is determined by volume, hub size and mounting position of the seal. Refer to installation data table on page F47 for specific amounts required.

Splices and taps shall not be made in fittings intended only for sealing with

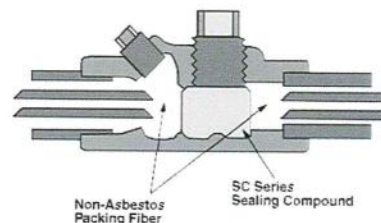

Schematic drawings illustrate the application of sealing compound, fiber dams, and installed seal with drain.

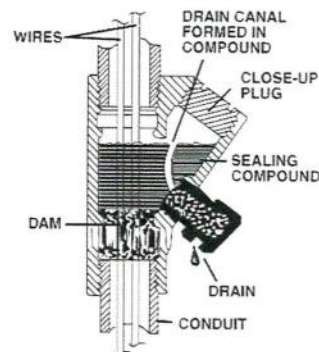

compound, nor shall other fittings in which splices or taps are made be filled with compound.

Killark sealing fittings are produced with utmost care to insure a substantial margin of safety. Threads are clean, deep, and snug. When properly installed with Killark sealing compound (SC Type) and Killark non-asbestos fiber (PF Type) for the dams, you can be sure your installation will provide more than adequate safety.

G) ENY 1, 2, & 3 Series is suitable for Class I, Zone 1, Groups A, B, C, & D; EYS, EY, & EYD Series are suitable for Class I, Groups C & D.

I) ENY 1, 2, & 3 Series is suitable for Class I, Zone 1, Groups IIC, IIB, IIA; EYS, EY/EYD Series and suitable for Class I, Zone 1 Groups IIB, IIC.



Enclosure Terminations and Seals

ENY/EYS SERIES • FITTINGS
SEALING FITTINGS

F45



ENY-1, 2, 3
Class I, Div. 1 & 2, Groups A,B,C,D
Class I, Zone 1, Groups IIC, IIB, IIA
Class II, Div. 1 & 2, Groups E,F,G
Class III

ENY-4, 5 & 6 & EYS Series
Class I, Div. 1 & 2, Groups C,D
Class I, Zone 1, Groups IIB, IIA
Class II, Div. 1 & 2, Groups E,F,G
Class III

Listed File No. E10514
 Certified File No. LR11716

FEATURES-SPECIFICATIONS

Material/Finish

(less than 4/10 of 1%)

- Electrostatically applied powder coating

Duraloy Iron

- Tri-Coat Finish of electrozinc, chromate sealant, and electrostatically applied powder coating

ENY SEALING FITTINGS						ENY WITH NIPPLE	
HUB SIZE	CATALOG NUMBER		DIMENSIONS		TURNING RADIUS	CATALOG NUMBER	
	KILLARK ALUMINUM	DURALOY IRON	A	B		KILLARK ALUMINUM	DURALOY IRON
1/2"	ENY-1 ^⑥	ENY-1M ^⑥	3-15/16"(100)	1-13/16"(46)	1-3/16"(30)	ENY-1-T ^⑥	ENY-1-TM ^⑥
3/4"	ENY-2 ^⑥	ENY-2M ^⑥	4-1/16"(103)	2-1/16"(52)	1-9/32"(33)	ENY-2-T ^⑥	ENY-2-TM ^⑥
1"	ENY-3 ^⑥	ENY-3M ^⑥	4-25/32"(121)	2-11/32"(60)	1-13/32"(36)	ENY-3-T ^⑥	ENY-3-TM ^⑥
1-1/4"	ENY-4	ENY-4M	5-3/8"(137)	3"(76)	1-25/32"(45)	ENY-4-T	ENY-4-TM
1-1/2"	ENY-5	ENY-5M	5-11/16"(144)	3-1/4"(83)	1-29/32"(48)	ENY-5-T	ENY-5-TM
2"	ENY-6	ENY-6M	6-3/8"(162)	3-15/16"(100)	2-5/16"(59)	ENY-6-T	ENY-6-TM

EYS SEALING FITTINGS						EYS WITH NIPPLE	
HUB SIZE	CATALOG NUMBER		DIMENSIONS		TURNING RADIUS	CATALOG NUMBER	
	KILLARK ALUMINUM	DURALOY IRON	A	B		KILLARK ALUMINUM	DURALOY IRON
1/2"	EYS-1 ^⑥	—	3-15/16"(100)	1-13/16"(46)	1-3/16"(30)	EYS-1-T ^⑥	EYS-1-TM ^⑥
3/4"	EYS-2 ^⑥	—	4-1/16"(103)	2-1/16"(52)	1-9/32"(33)	EYS-2-T ^⑥	EYS-2-TM ^⑥
1"	EYS-3 ^⑥	—	4-25/32"(121)	2-11/32"(60)	1-13/32"(36)	EYS-3-T ^⑥	EYS-3-TM ^⑥
1-1/4"	EYS-4	—	5-3/8"(137)	3"(76)	1-25/32"(45)	EYS-4-T	EYS-4-TM
1-1/2"	EYS-5	—	5-11/16"(144)	3-1/4"(83)	1-29/32"(48)	EYS-5-T	EYS-5-TM
2"	EYS-6	—	6-3/8"(162)	3-15/16"(100)	2-5/16"(59)	EYS-6-T	EYS-6-TM
2-1/2"	EYS-7	EYS-7M	7-5/8"(194)	4-1/2"(114)	4-1/8"(105)	EYS-7-T	EYS-7-TM
3"	EYS-8	EYS-8M	7-5/8"(194)	4-1/2"(114)	4-3/8"(111)	EYS-8-T	EYS-8-TM
3-1/2"	EYS-9 ^①	EYS-9M ^①	7-1/8"(181)	5-3/16"(132)	4-3/4"(121)	EYS-9-T ^①	EYS-9-TM ^①
4"	EYS-0 ^①	EYS-0M ^①	7-1/8"(181)	5-3/16"(132)	4-3/4"(121)	EYS-0-T ^①	EYS-0-TM ^①

Dimensions

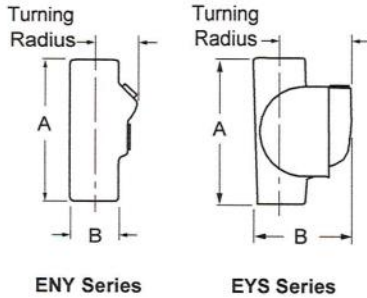

^⑥ ENY 1, 2, & 3 Series is suitable for Class I, Groups A, B, C, & D.
EYS, EY, & EYD Series are suitable for Class 1, Groups C & D.
^① CSA Certified for Class I, Group D only.



Enclosure Terminations and Seals

F46

**EY/EYD SERIES • FITTINGS
SEALING FITTING**



EY **EY with Nipple**
(For Vertical Conduit)



EYD **EYD with Nipple**
(Drain/Seal for vertical conduit)

EY & EYD Series
Class I, Div. 1 & 2, Groups C,D
Class I, Zone 1, Groups IIB, IIA
Class II, Div. 1 & 2, Groups E,F,G
Class III

Listed File No. E10514

Certified File No. LR11716

FEATURES-SPECIFICATIONS

Material/Finish

Copper-free Aluminum
(less than 4/10 of 1%)

- Electrostatically applied powder coating

Duraloy Iron

- Tri-Coat Finish of electrozinc, chromate sealant, and electrostatically applied powder coating

Dimensions

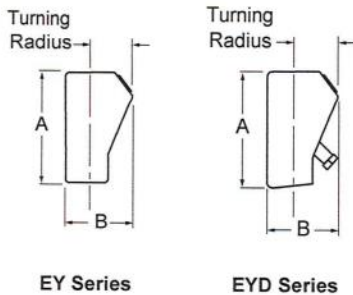

EY Series

EYD Series

EY SEALING FITTINGS						EY WITH NIPPLE	
HUB SIZE	CATALOG NUMBER		DIMENSIONS		TURNING RADIUS	CATALOG NUMBER	
	KILLARK ALUMINUM	DURALOY IRON	A	B		KILLARK ALUMINUM	DURALOY IRON
1/2"	EY-1	EY-1M	3-1/16"(78)	2-1/8"(54)	2-1/4"(57)	EY-1-T	EY-1-TM
3/4"	EY-2	EY-2M	3-1/16"(78)	2-11/16"(68)	1-15/16"(49)	EY-2-T	EY-2-TM
1"	EY-3	EY-3M	4-9/32"(109)	3-1/8"(79)	2-1/4"(57)	EY-3-T	EY-3-TM
1-1/4"	EY-4	EY-4M	5-1/8"(130)	3-7/8"(98)	2-7/8"(73)	EY-4-T	EY-4-TM
1-1/2"	EY-5	EY-5M	5-1/8"(130)	4-5/8"(117)	3-7/16"(87)	EY-5-T	EY-5-TM
2"	EY-6	EY-6M	5-1/8"(230)	5-11/16"(144)	4-1/4"(108)	EY-6-T	EY-6-TM
2-1/2"	EY-7	EY-7M	7"(178)	6-5/16"(160)	4-5/8"(117)	EY-7-T	EY-7-TM
3"	EY-8	EY-8M	7"(178)	6-5/16"(160)	4-5/8"(117)	EY-8-T	EY-8-TM
3-1/2"	EY-9 ^{G)}	EY-9M ^{G)}	8-3/4"(222)	7-1/8"(181)	5-3/8"(138)	EY-9-T ^{G)}	EY-9-TM ^{G)}
4"	EY-0 ^{G)}	EY-0M ^{G)}	8-3/4"(222)	7-1/8"(181)	5-3/8"(138)	EY-0-T ^{G)}	EY-0-TM ^{G)}

EYD SEALING FITTINGS						EYD WITH NIPPLE	
HUB SIZE	CATALOG NUMBER		DIMENSIONS		TURNING RADIUS	CATALOG NUMBER	
	KILLARK ALUMINUM	DURALOY IRON	A	B		KILLARK ALUMINUM	DURALOY IRON
1/2"	EYD-1	EYD-1M	4-9/32"(109)	3-1/8"(79)	2-1/4"(57)	EYD-1-T	EYD-1-TM
3/4"	EYD-2	EYD-2M	4-9/32"(109)	3-1/8"(79)	2-1/4"(57)	EYD-2-T	EYD-2-TM
1"	EYD-3	EYD-3M	4-9/32"(109)	3-1/8"(79)	2-1/4"(57)	EYD-3-T	EYD-3-TM
1-1/4"	EYD-4	EYD-4M	5-1/8"(130)	3-7/8"(98)	2-7/8"(73)	EYD-4-T	EYD-4-TM
1-1/2"	EYD-5	EYD-5M	5-1/8"(130)	4-5/8"(117)	3-7/16"(87)	EYD-5-T	EYD-5-TM
2"	EYD-6	EYD-6M	5-1/8"(130)	5-11/16"(144)	4-1/4"(108)	EYD-6-T	EYD-6-TM
2-1/2"	EYD-7	EYD-7M	7"(178)	6-5/16"(160)	4-5/8"(117)	EYD-7-T	EYD-7-TM
3"	EYD-8	EYD-8M	7"(178)	6-5/16"(160)	4-5/8"(117)	EYD-8-T	EYD-8-TM
3-1/2"	EYD-9 ^{G)}	EYD-9M ^{G)}	8-3/4"(122)	7-1/8"(181)	5-3/8"(137)	EYD-9-T ^{G)}	EYD-9-TM ^{G)}
4"	EYD-0 ^{G)}	EYD-0M ^{G)}	8-3/4"(122)	7-1/8"(181)	5-3/8"(137)	EYD-0-T ^{G)}	EYD-0-TM ^{G)}

^{G)} CSA Certified for Class I, Group D only.



Enclosure Terminations and Seals

ENY/EYS/EY/EYD SERIES • FITTINGS
SEALING MATERIALS

F47



Sealing Compound



Packing Fiber



Thread Lubricants

FEATURES-SPECIFICATIONS

Series SC/PF/LUBG

Sealing Materials

Sealing Compound

SC Series Sealing compound is a cement used extensively for sealing conduit to prevent the spread of explosive gases. It is non-shrinking and a secure seal is formed. SC Series resists acids, water, oil, etc. It is UL Listed for use with Killark ENY, EY, and EYS Series. Also CSA certified for use with any CSA certified sealing fitting.

Packing Fiber

Killark's Packing Fiber is made from an environmentally safe, non-asbestos material. It is easy to use and forms a positive dam to hold compound (Killark SC Type) in ENY, EY, and EYS Series fittings.

Thread Lubricants

Two special blends of lubricants have been developed by Killark for use with threaded joints. These lubricants are to be used to prevent galling of pipe threads when threaded into a coupling, junction box, etc. They insure a quick release of undamaged male and female threads when parts are disassembled.

LUBG is a general purpose lubricant to be used in temperatures ranging from 0° to 125°F.

LUBT is a high-quality lubricant to be used in temperatures ranging from -40° to +500°F. It is recommended to be used on hazardous location lighting fixtures.

OUNCES REQUIRED PER FITTING				
HUB SIZE	SEALING COMPOUND			PACKING FIBER
	ENY ^{G)}	EYS ^{G)}	EY/EYD	
1/2"	1.5 oz.	3.0 oz.	1.0 oz.	1/16 oz.
3/4"	2.0 oz.	3.0 oz.	2.0 oz.	1/8 oz.
1"	3.0 oz.	8.0 oz.	4.5 oz.	1/4 oz.
1-1/4"	6.5 oz.	8.5 oz.	7.5 oz.	1/2 oz.
1 1/2"	8.5 oz.	17.5 oz.	12.0 oz.	1 oz.
2"	15.0 oz.	27.0 oz.	24.0 oz.	2 oz.
2-1/2"	—	42.0 oz.	44.0 oz.	3 oz.
3"	—	47.0 oz.	44.0 oz.	4 oz.
3-1/2"	—	56.0 oz.	75.0 oz.	6 oz.
4"	—	56.0 oz.	75.0 oz.	9 oz.

^{G)} ENY/EYS suitable for both horizontal or vertical applications.

SEALING COMPOUND	
CATALOG NUMBER	SIZE PACKAGE
SC-4 OZ	4 oz.
SC-8 OZ	8 oz.
SC-1 LB	1 lb.
SC-5 LB	5 lbs.

PACKING FIBER	
CATALOG NUMBER	SIZE PACKAGE
PF-2	2 oz.
PF-4	4 oz.
PF-16	1 lb.

THREAD LUBRICANTS	
CATALOG NUMBER	CONTAINER PACKAGE
LUBT-2	2 oz.
LUBG-6	6 oz.



Enclosure Terminations and Seals

Explosionproof and Dust-Tight Fittings and Accessories

EXPLOSIONPROOF AND DUST-TIGHT SEALING FITTINGS CLASS I, GROUPS B*, C & D; CLASS II, GROUPS E, F & G; NEMA 7 & NEMA 9



XYB-XYBM

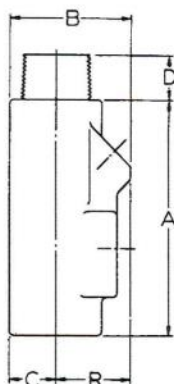

Sealing Fittings are required in Hazardous Locations and are used to isolate arc-producing devices in conduit and wiring systems, and to prevent the passage of explosive pressures from one area to another.

FOR HORIZONTAL AND VERTICAL MOUNTING - Type XYB and XYBM are suitable for either horizontal or vertical mounting and are provided with threaded plugged openings into which fiber and cement can be placed to form effective seal. XYB has female ends for conduit entrance. The XYBM has female ends with a removable threaded nipple.

*1/2", 3/4", 1" sizes Class I, Group B, C, D, Class II, E, F, G.

1 1/4", 1 1/2", 2", 2 1/2", 3", 3 1/2", 4" sizes Class I, Group C, D
Class II, E, F, G

CSA Certified LR27991

UL Listed E10493

Catalog No. Description	Conduit Size (In.)	Ounces Req. For Each Sealing Fitting		Standard Package	
		Cement	Fiber	Qty.	Tot. Wt. Lbs.
Female-Female					
XYB-2	1/2	1	1/8	5	2.1
XYB-3	3/4	2	1/4	5	2.6
XYB-4	1	3	1/4	5	3.7
XYB-5	1-1/4	6	3/8	2	2.5
XYB-6	1-1/2	9	1/2	2	3.2
XYB-8	2	18	3/4	2	5.6
XYB-10	2-1/2	23	1-1/2	2	6.2
XYB-12	3	48	3-1/8	1	6.0
XYB-14	3-1/2	70	4-1/2	1	6.8
XYB-16	4	90	6	1	8.3

Catalog No. Description	Conduit Size (In.)	Ounces Req. For Each Sealing Fitting		Standard Package	
		Cement	Fiber	Qty.	Tot. Wt. Lbs.
Male-Female					
XYBM-2	1/2	1	1/8	5	2.2
XYBM-3	3/4	2	1/4	5	2.7
XYBM-4	1	3	1/4	5	3.8
XYBM-5	1-1/4	6	3/8	2	2.6
XYBM-6	1-1/2	9	1/2	2	3.4
XYBM-8	2	18	3/4	2	5.9
XYBM-10	2-1/2	23	1-1/2	2	6.8
XYBM-12	3	48	3-1/8	1	6.3
XYBM-14	3-1/2	70	4-1/2	1	7.3
XYBM-16	4	90	6	1	8.8

Conduit Size	Nominal Dimensions (Inches)				
	A	B	C	(XYBM Series Only) D	Turn Radius R
1/2	3-19/32	1-13/16	5/8	11/16	1-3/16
3/4	3-25/32	2-1/16	3/4	15/16	1-5/16
1	4-3/8	2-5/16	7/8	15/16	1-7/16
1-1/4	5-5/32	2-13/16	1-1/16	1-1/16	1-3/4
1-1/2	5-11/16	3-3/16	1-3/16	1-3/16	2
2	6-13/16	3-7/8	1-1/2	1-7/16	2-3/8
2-1/2	7-1/2	4-1/2	1-7/8	1-5/8	2-11/16
3	9-9/16	5-1/2	2-3/16	1-7/8	3-5/16
3-1/2	9-1/2	6-1/6	2-3/8	2	3-11/16
4	9-9/16	6-1/2	2-5/8	2-1/8	3-7/8

Compliances

- NEC Class I, Groups B, C, D - Class II, Groups E, F, G
- UL Standard 886 - CSA Standard C22.2 No. 30

Enclosure Terminations and Seals

Explosionproof and Dust-Tight Fittings and Accessories

EXPLOSIONPROOF AND DUST-TIGHT SEALING FITTINGS CLASS I, GROUP D; CLASS II, GROUPS E, F & G; NEMA 7 & NEMA 9



XY 2-3-4



XYM 2-3-4



XY 5-6



XYM 5-6



XYC



XYCM



XYCS



XYCSM

Adalet Sealing Fittings are used to isolate arc-producing devices from wiring systems and to prevent the spread of explosive gases.

FOR VERTICAL MOUNTING

Types XY and XYM Fittings are for vertical mounting, and are provided with threaded plugged openings into which the sealing cement is poured. Sizes 1-1/4" x 1-1/2" have large plugged openings in the lower hub to facilitate packing fiber around the wires to form a dam. Type XYM's have removable threaded nipples. The two hubs are tapped simultaneously to assure alignment of the conduits, especially important to equipment manufacturers using short runs of conduit.

FOR HORIZONTAL & VERTICAL MOUNTING

Type XYC Fittings are for horizontal mounting only, with the cover opening in an upright position. XYCS fittings are for vertical or horizontal mounting, with removable threaded covers which can be turned to the desired position for pouring in the sealing cement. The covers are interchangeable. The male-to-female types have removable threaded nipple.

Ounces

Female/ Female	Male/ Female	Size (In.)	Sealing Cement	Packing Fibre	Qty	Weight Lbs.
XY2	XYM2	1/2	1	1/8	25	10
XY3	XYM3	3/4	1	1/4	25	10
XY4	XYM4	1	2	1/4	25	12-1/2
XY5	XYM5	1-1/4	4	3/8	10	7-1/2
XY6	XYM6	1-1/2	5	1/2	10	10
XYC2	XYC2M	1/2	2	1/8	25	13
XYC4	XYC4M	1	4-1/2	1/4	25	15
XYC5	XYC5M	1-1/4	8-1/2	3/8	10	10
XYC6	XYC6M	1-1/2	11-1/2	1/2	10	11
XYC8	XYC8M	2	13-1/2	3/4	10	12
XYC10	XYC10M	2-1/2	15	1-1/2	1	2
XYC12	XYC12M	3	31-1/2	3-1/8	1	3
XYC14	XYC14M	3-1/2	42-1/2	4-1/2	1	4
XYC16	XYC16M	4	51	6	1	5
XYC2S	XYC2SM	1/2	2	1/8	25	13
XYC4S	XYC4SM	1	3	1/4	25	15
XYC5S	XYC5SM	1-1/4	6-1/2	3/8	10	10
XYC6S	XYC6SM	1-1/2	10	1/2	10	11
XYC8S	XYC8SM	2	12-1/2	3/4	10	12
XYC10S	XYC10SM	2-1/2	13-1/2	1-1/2	1	2
XYC12S	XYC12SM	3	29-1/2	3-1/8	1	3
XYC14S	XYC14SM	3-1/2	40	4-1/2	1	4
XYC16S	XYC16SM	4	48-1/2	6	1	5

CSA Certified LR27991

UL Listed E10493

Compliances

- NEC Class I, Group D Class II, Groups E, F, G
- UL Standard 886 - CSA Standard C22.2 No. 30

Enclosure Terminations and Seals

EIH Instrument Enclosures

Cl. I, Div. 1 & 2, Groups B†,C,D
 Cl. II, Div. 1, Groups E,F,G
 Cl. II, Div. 2, Groups F,G
 Cl. III
 NEMA 3,4,7B†CD,9EFG

Explosionproof
 Dust-Ignitionproof
 Raintight
 Wet Locations
 Watertight

4A

Application:

- EIH instrument enclosures are used:
- to enclose instrumentation and control devices such as two-wire transmitters, flow measurement devices, temperature controls, level detectors, pressure switches, etc.
 - as an outlet box for pulling and splicing conductors
 - in hazardous, abusive and wet locations
 - to provide access to conductors for maintenance and future system changes

Features:

- 3/4" offset through feed hubs offer maximum interior space and greater working area
- 2" and 4" deep covers, solid or with glass lens
- Internal mounting pads for instrument mounting
- Internal ground screw for safe, continuous grounding
- Neoprene gasket provides a watertight seal for NEMA/EEMAC 4 and UL/CSA Type 4 applications.
- Wrenching lugs permit easy cover removal and tightening.
- Internal cover threads provide additional space inside body.
- External boss is suitable for drilling and tapping an additional conduit entry.

Standard Materials:

- Body and cover – copper-free aluminum
- Glass lens – heat tempered glass
- Gasket – neoprene

Standard Finishes:

- Corro-free™ epoxy powder coat (gray)



EIH21



EIH22

Hub Size*	Description	Cat. #
3/4	Body with 2" standard cover	EIH20
3/4	Body with 2" glass lens cover	EIH21
3/4	Body with 4" dome cover	EIH22
3/4	Body with 4" glass lens dome cover	EIH23

Options:

	Suffix to be Added to Cat. #
Cast mounting feet	MF
Natural finish.	Consult Cooper Crouse-Hinds
Additional drilled and tapped opening in external boss:	
1/2"	-1
3/4"	-2

Certifications and Compliances:

- NEC/CEC:
 - Class I, Division 1 & 2, Groups B†,C,D
 - Class II, Division 1, Groups E,F,G
 - Class II, Division 2, Groups F,G
 - Class III
- NEMA/EEMAC: 3,4,7BCD,9EFG
- UL Standard: 1203
- CSA Standard: C22.2 No. 30
- FM Classification No.: 3615
- ATEX Certificate EX-95.D, 3327 U

Dimensions

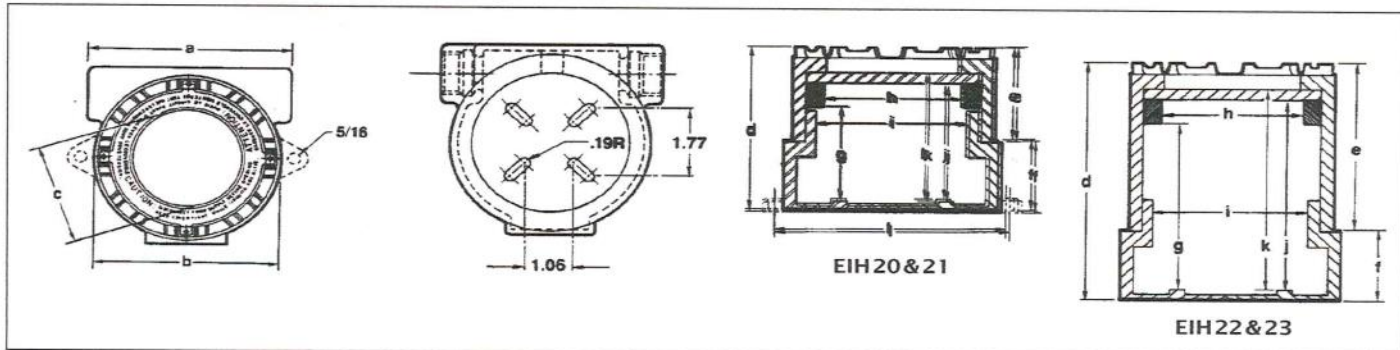

	a	b	c	d	e	f	g	h	i	j	k	l
EIH20	5.00	4.25	—	4.54	2.60	1.94	—	—	3.62	—	3.34	5.25
EIH21	5.00	4.25	2.60	4.54	2.60	1.94	2.75	2.73	3.62	3.10	—	5.25
EIH22	5.00	4.25	—	6.54	4.60	1.94	—	—	3.62	—	5.34	5.25
EIH23	5.00	4.25	2.60	6.54	4.60	1.94	4.68	2.73	3.62	5.03	—	5.25

* For 1/2" hub size, use RE21-SA.
 Dimensions are approximate, not for construction purposes.
 † For Group B applications, seal within 1 1/2" of enclosure in accordance with Sections 501-5 of the National Electrical Code as well as any other applicable codes.

Enclosure Terminations and Seals

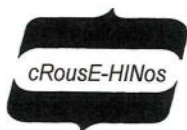

EIH/EIHT Instrument Enclosure Installation & Maintenance Information

IF 1179

SAVE THESE INSTRUCTIONS FOR FUTURE REFERENCE

EIH and EIHT Instrument Enclosures are designed to house instrumentation and control equipment as well as act as a conduit outlet body in hazardous, abusive and wet locations.

The EIH and EIHT enclosure is approved by Underwriters Laboratories Inc., Canadian Standards Association, Factory Mutual and CENELEC for use in Class I, Groups B*, Ct & D, Class II, Groups E, F & G and Class III hazardous (classified)

locations as defined by the National Electrical Code® and Canadian Electrical Code. It is also NEMA/UL/CSA Type 4 and IP66 rated for watertight applications.

* With conduit seals installed within 18 inches of enclosure. For CSA group C applications, unsealed conduit lengths must not exceed 5 ft (152 cm).

INSTALLATION

WARNING

If a heat producing instrument or device is mounted in the enclosure do not install in any classified location where the operating temperature of the enclosure exceeds the ignition temperature of the hazard present.

WARNING

Electrical power must be "OFF" before and during installation and maintenance.

1. EIH Instrument Enclosures are furnished with 3/4" NPT off set through feed cast hubs for conduit entries. EIHT Instrument Enclosures are supplied with 3/4" NPT off set through feed cast hubs on the power side and one 3/4" NPT hub on the instrument side for conduit entries. (Use Crouse-Hinds RE21-SA to reduce to 1/2" hubs)
2. Secure the enclosure to the conduit system. If the enclosure has mounting feet, select a mounting location that will provide sufficient strength and rigidity to support the enclosure as well as the enclosed device and wiring.

DIMENSIONS

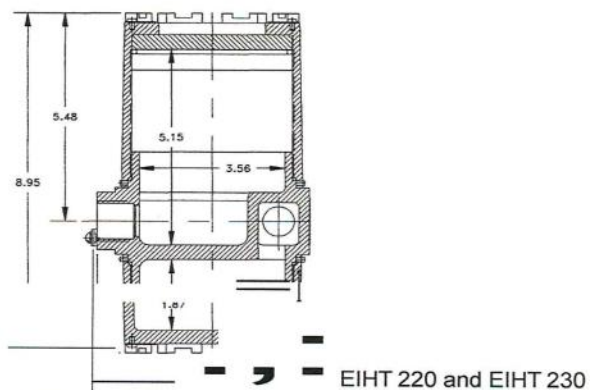
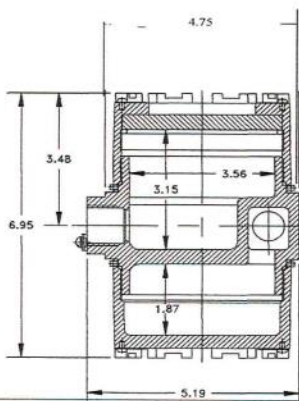
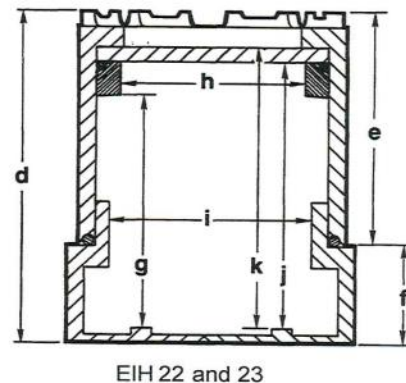
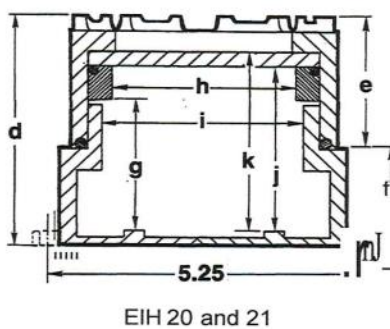
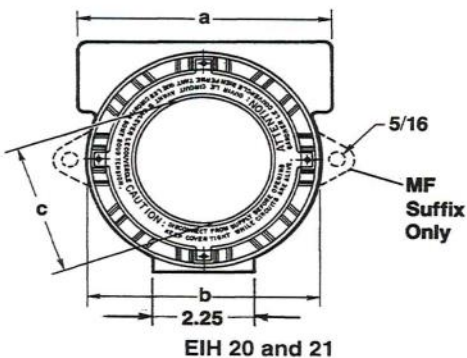

Type	a	b	c	d	e	f	g	h	i	j	k
EIH20	5.00	4.50	-	4.51	2.60	1.91	-	-	3.62	-	3.47
EIH21	5.00	4.50	2.60	4.51	2.60	1.91	2.45	2.73	3.62	3.09	3.50
EIH22	5.00	4.50	-	6.51	4.60	1.91	-	-	3.62	-	5.47
EIH23	5.00	4.50	2.60	6.51	4.60	1.91	4.45	2.73	3.62	5.09	5.50

Enclosure Terminations and Seals

INSTALLATION continued

CAUTION

- Select a mounting location so that the enclosure will not be subjected to impact by heavy objects. Impacts can damage enclosed devices or glass lens.
- The hazardous location information specifying class and group listing of each instrument enclosure is marked on the nameplate of each enclosure.
- All unused conduit openings must be plugged. Plug unused conduit openings with Crouse-Hinds PLG2. Plugs must be a minimum of 1/8" thick and engage a minimum of 5 full threads.

3. Install Crouse-Hinds EYS Sealing Fittings required by Section 501-5 and/or 502-5 of the National Electrical Code® and Section 18 of the Canadian Electrical Code as well as any other applicable local codes and when enclosure is installed in Class I Group B hazardous locations. (For CSA Group C applications, unsealed conduit lengths must not exceed 5 ft. or 152 cm).
4. Unthread instrument (and power side) covers and carefully set aside to prevent damage to the cover threads and glass lens (when glass lens cover is used).
5. Pull wires into enclosure making certain they are long enough to make the required connections and to remove

the instrument or power supply if servicing is required. Install instrument and a power supply, if applicable and make all electrical connections. (If installing an EIHT and connections need to be made between the two halves of the EIHT enclosure see DRILLING BETWEEN ENCLOSURE WALL section of instruction sheet.)

NOTE: When installing device be sure to check instrument dimensions to avoid interference with clamping ring on glass lens units and the cover on standard units.

6. Test wiring for correctness by checking continuity and also check for unwanted grounds with insulator resistance tester. Make sure test equipment being used will not damage instrument to be housed in the EIH or EIHT instrument enclosure.
7. Carefully rethread cover to enclosure housing. Tighten cover until cover flange contacts body face.

CAUTION

Use care to prevent dirt, grit or other foreign material from lodging on threads. If any such material settles on these threads, clean them with Kerosene or Stoddard solvent*, then relubricate with Crouse-Hinds Type STL thread lubricant.

*To avoid the possibility of an explosion, oxidation and corrosion, do not use gasoline or similar solvent.

8. Tighten cover set screws to prevent cover from loosening under vibration.

DRILL & TAP INTERNAL MOUNTING PADS (EIH only)

1. Prepare a template or mark the position of the device mounting holes on the mounting pads in the bottom of the enclosure. See Figure 1.
2. Holes can be drilled and tapped in the mounting pads. See Figure 2.

WARNING

To maintain the explosionproof integrity of the enclosure with a screw in a tapped mounting pad hole, there must be a minimum of 1/16" of material between the drill point and the back wall. If for any reason a screw will not be threaded into the drilled hole a minimum of 1/8" of material must remain between the drill point and the back wall.

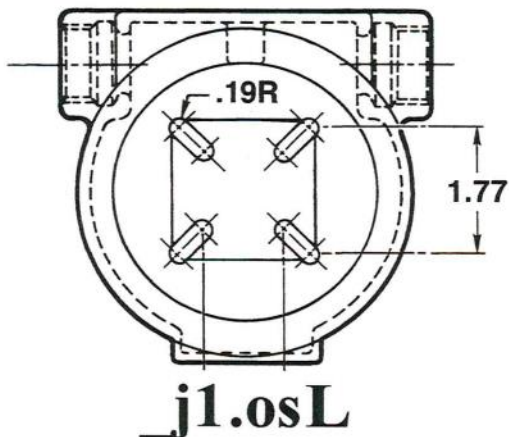

Figure 1. Internal Mounting Pad Dimensions

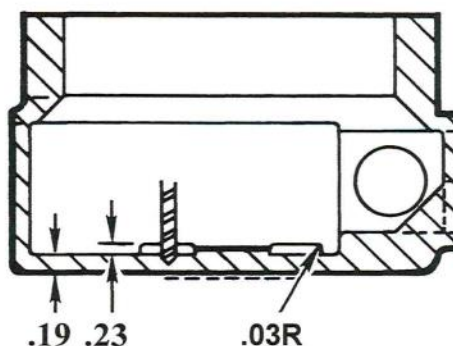

Figure 2. Mounting Pad and Back Wall Dimensions

Enclosure Terminations and Seals

DRILLING AND TAPPING FOR CONDUIT ENTRIES (EIH only)

The external pad has a wall thickness suitable for drilling and tapping an additional 3/4" or 1/2" conduit entry.

WARNING

The size of the pad only allows for either (1) 3/4" or (1) 1/2" NPT conduit entry. DO NOT attempt to drill and tap two conduit entries or an entry larger than 3/4".

NOTE: The conduit entrance must lie within the shaded area outlined in Figure 3.

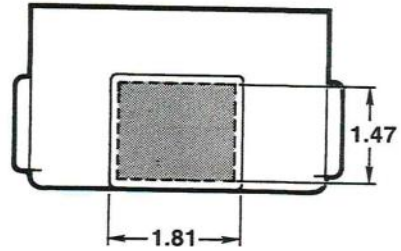

Figure 3.
Dimensions Suitable For Drilling and Tapping of External Pad.

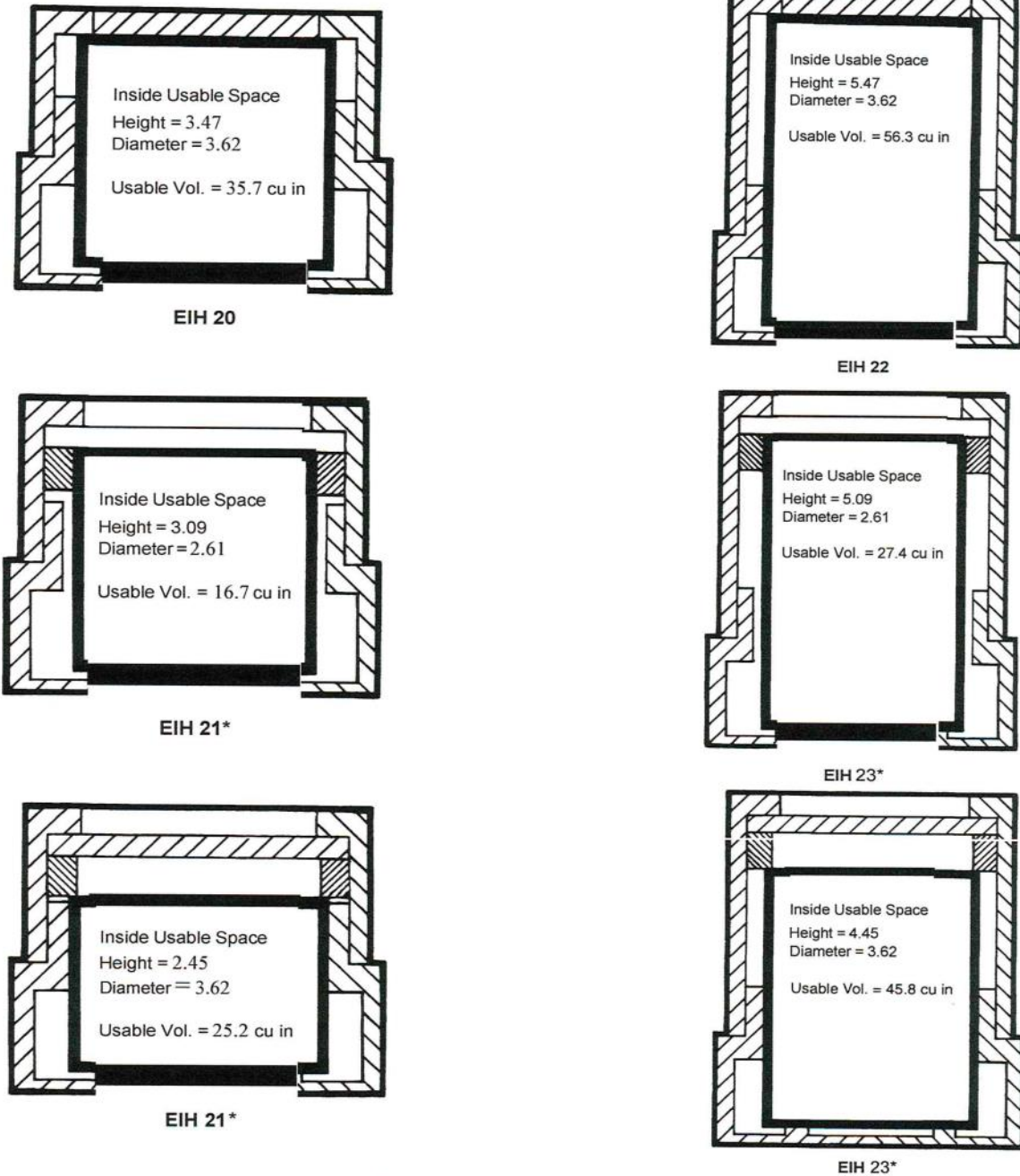

Figure 4. Internal Usable Space

*For EIH21 and 23, determine usable volume based on diameter and height of the instrument to be enclosed.

Enclosure Terminations and Seals

DRILLING AND TAPPING FOR CONDUIT ENTRIES (EIH only) continued

Female conduit entries must be taper tapped with the thread form and taper (3/4 in. per ft.) conforming to NPT. A standard NPT male gage must enter the tapped opening 1-1/2 turns past the gage notch. The opening is tapped deeper than standard NPT gage to ensure a minimum of five full threads engagement with standard NPT threaded conduit (refer to current NEMA FB-1).

Opening may be tapped to accept listed reducers that provide an integral conduit stop or openings may be tapped and counterbored 1/16 to 1/8 inch larger than conduit O. D. to a depth that will still provide a tapped surface of sufficient length for the number of threads within the limits shown in Table 1. This will allow assembly of a conduit bushing to the end of the conduit protruding through the wall.

TABLE 1

Number of threads in a conduit opening without a conduit stop. (Minimum 5 threads, maximum 20 threads per inch.)		
Trade Size of Conduit (Inch)	Number of Threads per Inch	Maximum Number of Threads
1/2	14	7
3/4	14	7

CAUTION

Sealing fittings must be installed with access allowing the dams to be made and the sealing compound to be properly poured.

DRILLING BETWEEN ENCLOSURE WALL (EIHT only)

Up to six 1/4" holes can be drilled between the wall of the two sides of the EIHT enclosure for pass throughs. The minimum spacing between holes must be 0.187 inches.

1. Remove both threaded covers before attempting to drill holes through the EIHT wall.
2. See figure 5 for defined area for pass throughs.

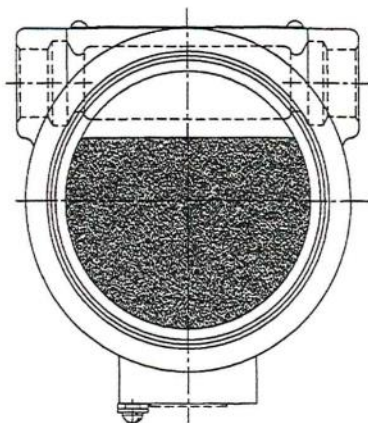

Figure 5

MAINTENANCE

WARNING

Always disconnect primary power source before opening enclosure for inspection or service.

1. Frequent inspection should be made. A schedule for maintenance checks should be determined by the environment and frequency of use. It is recommended that it should be at least once a year.
2. Perform visual, electrical and mechanical checks on all components on a regular basis.
 - Visually check for undue heating evidenced by discoloration of wires or other components, damaged or worn parts, or leakage evidenced by water or corrosion in the interior.
 - Electrically check to make sure that all connections are clean and tight and that the device is operating properly.

All statements, technical information and recommendations contained herein are based on information and tests we believe to be reliable. The accuracy or completeness thereof are not guaranteed. In accordance with Crouse-Hinds "Terms and Conditions of Sale", and since conditions of use are outside our control, the purchaser should determine the suitability of the product for his intended use and assumes all risk and liability whatsoever in connection therewith.

Field Calibration Check Procedure for 9500P Electronics

The 9500P electronic signal conditioner output can be checked by simulating the voltage output of the Flow sensor with an external DC voltage source.

1. Turn off power to flow meter.
- 2A. For Integral 9500P:
 - 2A1 Remove push-on jumper across pins 4 and 5 of TB1 (located above Zero and Span Pots on Logic Board as shown below).
 - 2A2 On TB1, connect an external variable DC voltage source, negative to Pin 2 and positive to Pin 5 (pin 1 is closest to the front).
- 2B. For Remote 9500P:
 - 2B1 Disconnect cable from electronics terminal TB2 (Located on board opposite side of the Logic Board).
 - 2B2 Connect an external variable DC voltage source to terminal TB2, negative to terminal 2 and jump it to 3. Connect the positive to terminal 4.
3. Apply power to the electronics.
4. Locate the calibration specification sheet in the instruction manual labeled "Component Values Determined at Calibration".
5. Turn on variable DC voltage source and set DC voltage to the 10% of full scale flow rate transducer voltage (EXC). The display, if available, should indicate the 10% of full scale flow rate. The DC mA Output should be 5.6mA (10% of scale). If the mA output is not correct, adjust ZERO potentiometer R6 until 5.6 mA.
6. Set the DC voltage to the 90% of full scale flow rate transducer voltage (EXC). The display, if available should indicate the 90% of full scale flow rate. The DC mA output should be 18.4 mA. If the mA output is not correct, adjust SPAN potentiometer R7 until 18.4 mA. You may have to return to step #6 if any adjustments were made due to the ZERO and SPAN potentiometers adjustments offset each other a little.
7. After the 10% and 90% of full scale flow rates are checked, check 0, 20, 30, 40, 50, 60, 70, 80, and 100% points.
8. Turn off power to the DC Voltage Source and flow meter.
9. Disconnect the DC Voltage Source.
- 10A. For Integral 9500P, place jumper back on across pins 4 and 5 on TB1.
- 10B. For Remote 9500P, reconnect the cable to electronics terminal TB2.
11. Turn on power to flow meter.
12. If procedure does not prove satisfactory, recheck steps taken and if necessary contact Thermal Instrument Company for assistance.

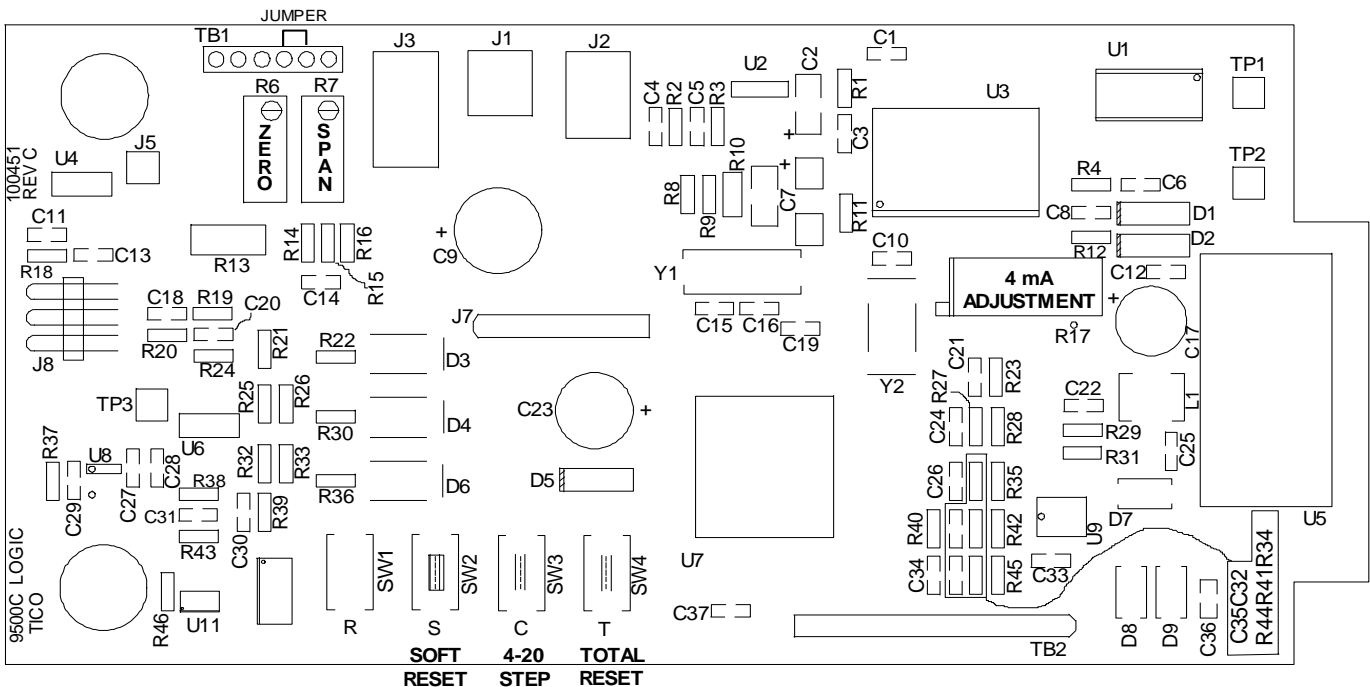

Troubleshooting

Troubleshooting of a malfunctioning flow meter is a process of isolating the particular circuit area which is out of range and then finding the components causing the failure. Before looking into the possible circuit problems it will be profitable in most cases to first determine that the problem is NOT internal to the electronics. As odd as it may seem, most apparent flow meter malfunctions are a result of incorrect installation or changes in process operating conditions.

Typical installation problems are as follows:

- Fluid not flowing properly through pipe

- Flow rate for the temperature is out of calibration range

- Fluid not identical to calibration fluid (Example: Air instead of CO₂ or Water instead of Glycol)

- Fluid has coated the flow element (Example: Very dirty gas or liquid that leaves a film or layers)

- Flow element installed too close to upstream or downstream flow disturbance (Minimum 10 pipe diameters upstream and 5 pipe diameters downstream)

- Power not on or incorrect voltage (Example: Connecting 24 VDC in place of the 110 VAC)

- Flow element wiring incorrect

- Output wiring incorrect

For installations that had been operating correctly it is frequently helpful to review the above list since changes made to the process, piping, or wiring have been known to effect flow meter performance.

If a problem has been identified from the above list and cannot be corrected, it will be helpful to discuss the situation with Thermal Instrument Company for possible solutions (new calibration or meter modifications).

Troubleshooting—Continued

How to check flow meter sensors and switch to spare sensors if necessary

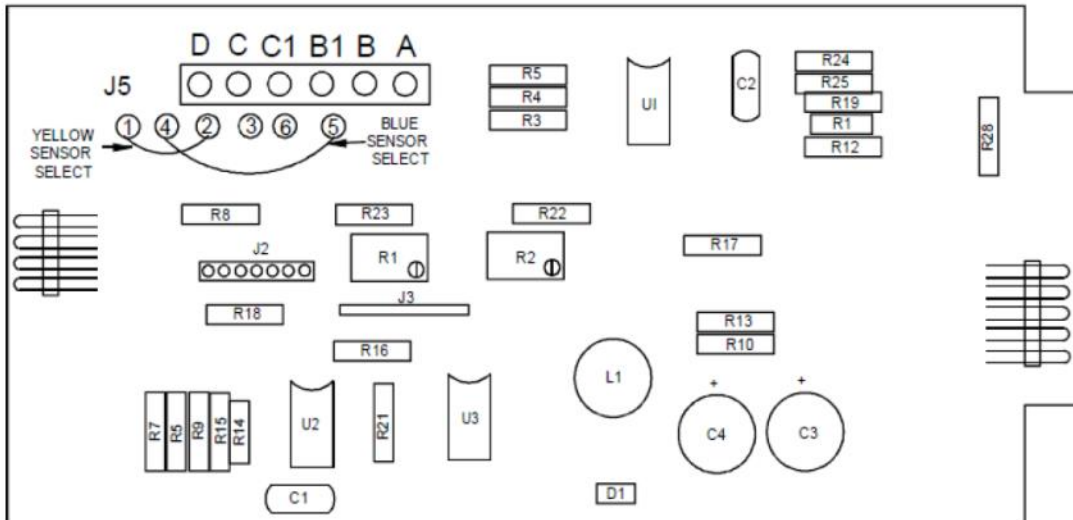

The sensors are terminated on terminal strip J5. Sensor resistance at 75°F in Ohms approximate:

Primary Flow:	A-B \approx 50 Ω
Spare Flow:	A-B1 \approx 50 Ω
Primary Temperature:	C-D \approx 100 Ω or 110 Ω
Spare Temperature:	C1-D \approx 100 Ω or 110 Ω

To measure sensor resistance:

1. Power meter off
2. Use Ohm meter to measure between
 - Primary Flow sensor A-B will read 40 Ω to 45 Ω
 - Spare Flow sensor A-B1 will read 50 Ω
 - Primary Temperature sensor C-D will read 41 Ω to 48 Ω
 - Spare Temperature sensor C1-D will read 100 Ω to 110 Ω

(Resistance will vary with temperature and the primary sensors in-circuit will be lower value)

Spare Sensors:

To connect Spare Flow, unsolder the blue jumper wire from B (5) and move it to B1 (6)

To connect Spare Temperature, unsolder the yellow jumper wire from C (2) and move it to C1 (3)

There is no need to change to spare sensors unless primary sensors are open or shorted.

The flow signal can be read at terminals D (+) and terminal A (-) with a digital voltmeter. This voltage can be located and read as flowrate from the Parts List or Flow Curve for the serial number unit in the manual.

If there are any questions about measured flowrate voltage and output, contact Thermal Instrument Co.

Email: Techsupport@thermalinstrument.com

Phone: (215) 355-8400 then touch 3 for Tech Support

Troubleshooting—Continued

The below steps should be followed if you have Remote 9500P Electronic Transmitter

Having eliminated external failure causes, check the following:

1. Check the flow element power supply voltage and its polarity from the remote electronics to the flow element. This should be around $27\text{ VDC} \pm 5\text{ VDC}$. The power supply is across pins 1 (+) and 2 (-) at the flow element and the remote electronics. If this voltage is zero then disconnect the cable going to the flow element and measure the power supply again at the remote electronics. If it is still zero volts, then the problem is the remote electronics (check the main power supply and the fuse or contact Thermal Instrument Company).
2. Measure the flow element signal voltage across the pins 3 (-) and 4 (+) at the flow element and the remote electronics. This is the raw DC voltage signal coming from the flow element to the remote electronics. This voltage will vary depending on the flow rate. This voltage should be within the calibrated range specified in the calibration specification sheet located in the flow meters operating manual labeled, "Component Values Determined at Calibration" or look at the meter's graph "Transducer Voltage vs. Flow Rate". If this voltage is too low around 1 VDC or too high around 18 VDC, then the problem is the flow element.

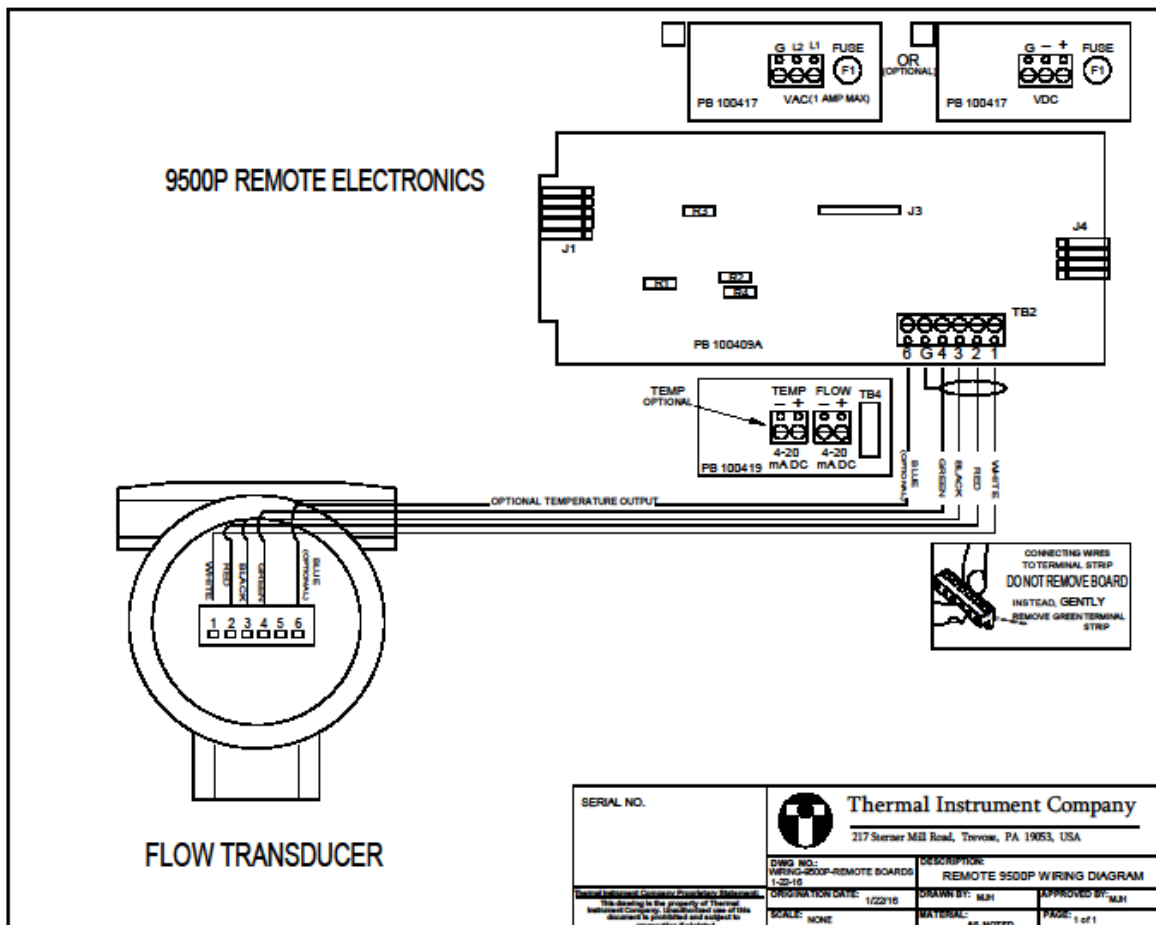

Summary

If you have any questions at all for Thermal Instrument Company, please do not hesitate to contact us at **(215) 355-8400**.

Spare Parts List:

110/220 VAC Fuse

They are readily available from Digi-Key (**1-800-344-4539**) as Part Number **WK4041BK-ND** or any other electronic supplier handling **Wickmann TR5 Sub-Miniature Fuses (UL 248-14)** or equivalent.

24 VDC Fuse

Wickmann Littelfuse 1 Amp Slow Blow 250 VAC - Digi-key Part # WK4048BK-ND.

www.digikey.com

Contact Thermal Instrument for other parts as needed.



www.ThermalInstrument.com

217 Sterner Mill Road

Trevose | PA | 19053 | USA

P: 215-355-8400

F: 215-355-1789