



217 Sterner Mill Road
Trevose, PA 19053 U.S.A.
Phone: 215-355-8400
Fax: 215-355-1789

OPERATIONS & INSTALLATION MANUAL

www.ThermalInstrument.com

Office@ThermalInstrument.com

CUSTOMER ORDER DETAILS

CUSTOMER NAME:

CUSTOMER PO#:

SERIAL NUMBER:

MODEL #:

APPLICATION SERVICE:

LINE SIZE:

OUTPUT:

ENCLOSURE RATING:

Killark— NEMA4, IP66, UL50E

Limatherm— IP66



**MODEL 9500P FLOW TRANSMITTER
WITH INSERTION OR IN-LINE
STYLE FLOW TRANSDUCER**

<u>TABLE OF CONTENTS:</u>	<u>PAGE</u>
Flow Meter Summary _____	3
Outline Dimensions _____	4 (Insertion Probe to inc. Packing Gland info)
Flow Curves & Calibration Spec Sheets _____	5 (A, B, C)
Field Wiring Diagrams _____	6 - 8
Meter Configuration Page Introduction _____	9
Guidelines & Precautions _____	10
Installation _____	12
Insertion Probe Installation Guide _____	16, 17
Operation & Info _____	18
Totalizer Reset _____	20
Bridge & Logic Board / Block Diagram _____	21 - 22
General Precautions _____	23
Instrument Housing _____	31
Field Calibration _____	36
(PSU) Instructions _____	37 - 39
Troubleshooting _____	40 - 46
Spare Parts _____	47

1A.2 Flow Meter Summary

TRANSMITTER:

Model #:

Metal :

ELECTRONICS LOCATION:

Integral Remote

DISPLAY TYPE:

None Flow Rate Flow Rate & Totalizer

OUTPUT SIGNAL(S):

- 4-20 mADC Flow Rate
- 4-20 mADC Temperature
- HART Communication -24 VDC Internal Power
- Modbus RS 485 (Included Flash Drive & Connection Cable)
- Pulse Output
- Pulse Setup: _____
- Other

INPUT POWER:

- CSA/UL 24VDC, 0.4A Max 100-240VAC, 50/60Hz, 0.4A max
- 24VDC, 1A Max Solar Powered
- 110 VAC, 50/60Hz, 0.5A Max Other:

Specific Outline Dimensions

All Flow Curves & Calibration Spec Sheet

1A.3 Wiring Diagrams

Details:

POWER OPTIONS, 4-20 MA FLOW OUTPUT (INTERNAL OR EXTERNAL POWER—See Note), HART, OPTIONAL 4-20MA TEMPERATURE OUTPUT, OPTIONAL PULSE OUTPUT, & OPTIONAL RS485 MODBUS OUTPUT

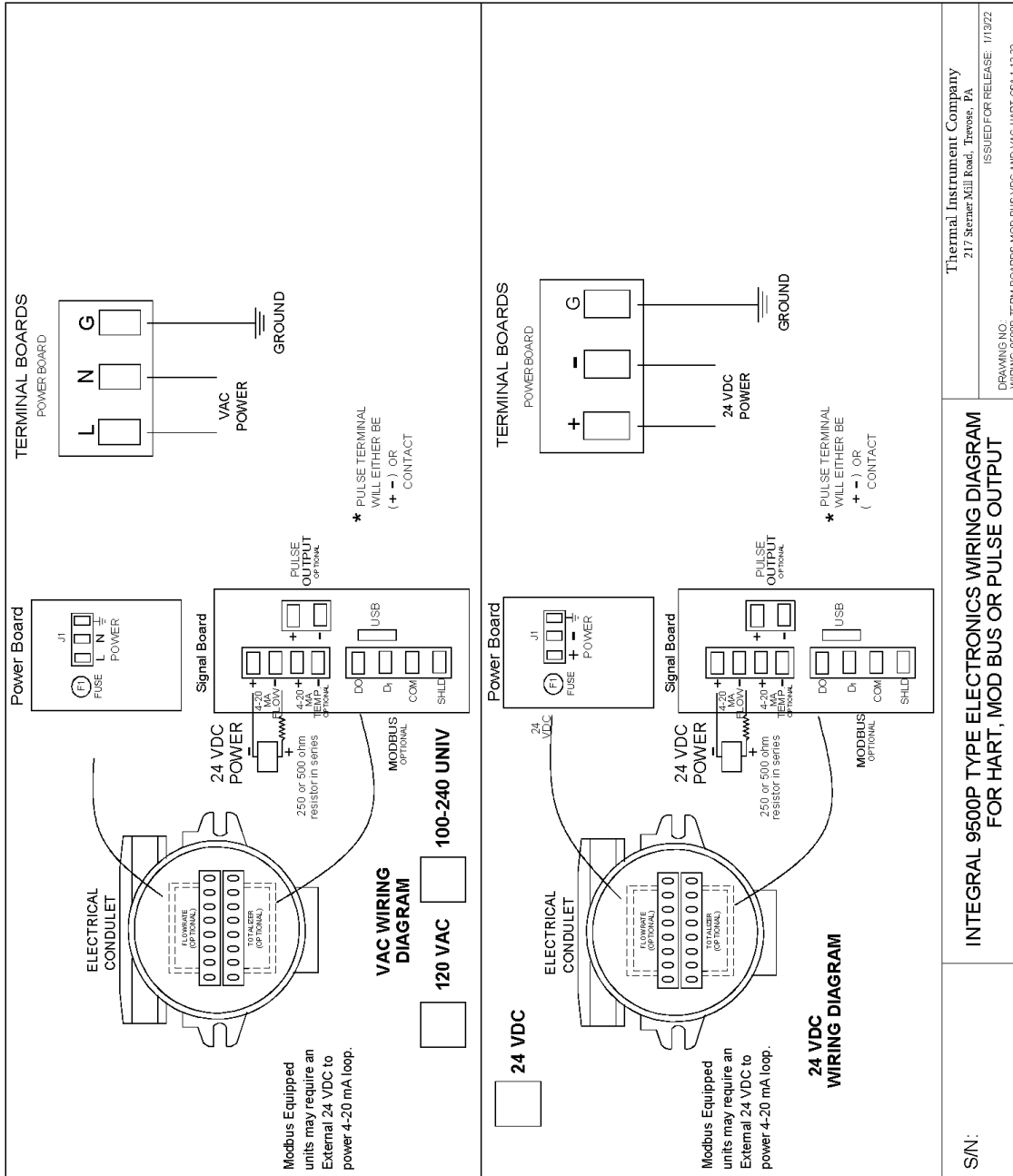

9500P Remote Wiring Diagram

NOTE: Below drawing shown as 4-20mA Flow / Temperature Output. Refer to Page 6 or Page 7 for Other Output Configurations.

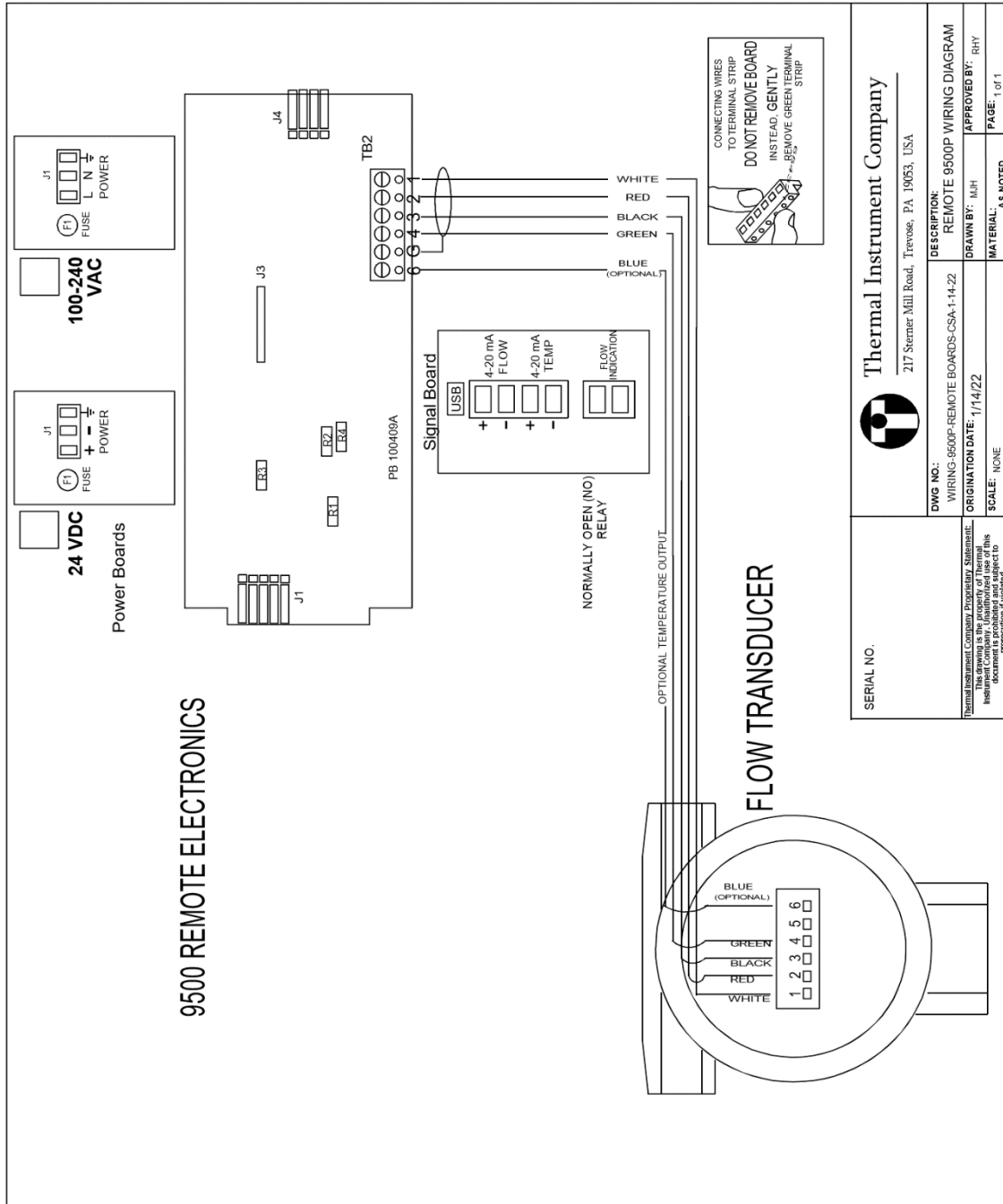

1.0 Introduction

1.1 Preface

These instructions contain all of the information that you will require for using this flow meter from Thermal Instrument Company.

These instructions are aimed at people mechanically installing the flow meter, connecting it electrically, configuring the parameters and commissioning it as well as service and maintenance engineers.

Note:

It is the responsibility of the customer that the instructions and directions provided in the manual are read, understood and followed by the relevant personnel before installing this device.

1.2 Flow Meter Configuration

Figure 1—Example Only

The Flow Meter Application Details can be confirmed on Page #3 of this manual or by reviewing the label and tags attached to each specific flow meter as shown in **Figure 1**.

Each flow meter has a specific Serial Number for identification purposes. **Note: When Receiving Remote Electronic Transmitters, the flow element and transmitter are a matched set.**

Items Inspection

1. Check for mechanical damage due to possible improper handling during shipment. All claims for damage are to be made promptly with the shipping company.
2. Make sure that the information on the product identifier plate and labels (**Figure 1** above) corresponds to the ordering information.



1.3 Further Information

The contents of these operating instructions shall not become part of or modify any prior or existing agreement such as the original quotation, or any other written communications.

These operating instructions are a guidance for this flow meter and do not create new warranties or modify the existing warranty.

Product Information available on our website:

<http://www.thermalinstrument.com>

2.0 General Guidelines & Precautions

Receiving / Inspection

- Unpack carefully and inspect overall condition
- Check the packing list to compare what you received is all there

If the above items are fine, then move on to the next section, otherwise contact our customer support group at **(215) 355-8400** and provide us with purchase order number or serial number of the flow meter.

Factory Calibration Note

This flow meter from Thermal Instrument Company has been factory calibrated to the specifications and flow range as stipulated by the customer. There is no need to perform any verification or calibration on this device prior to mounting and start-up in the application.

Prior to Installation

Qualified electrical personnel should be installing this instrument. The installation should be done per National Electrical Code and the power to the electrical wiring should be off during the installation. Where the instructions call out for use of electrical current, the operator assumes all responsibilities for conformance to safety and practices.

Alerts

This flow meter is not designed for weld-in place applications with the exception of the UHP (Ultra High Pure) in-line flow designs. The conventional welding technique can cause damage to the Nickel or Platinum sensors from the current being passed from ground to the hot weld side.

Damage due to moisture ingress into the enclosure is not covered under the warranty of this product and proper conduit seals must be applied for all-weather conditions. This flow transmitter contains electrostatic discharge (ESD) sensitive components, so use proper ESD precautions when handling the device.

Verify Mounting Area for Insertion or In-Line Flow design to make certain that everything fits properly.

Installation Point

Make sure that there are 10 pipe diameters upstream and 5 pipe diameters downstream of the flow meter from any bends or interferences in the process piping or ductwork in order to achieve the greatest accuracy.

Mechanical Care of Enclosure

Be careful of the enclosed electronics when removing the conduit cover. After the initial installation, never open the conduit when the power is connected, especially in a classified hazardous area. Gently lift the cover from the 9500P electronic assembly and place it in a safe location where dirt cannot get inside or, if the display option has been selected, where dirt can get on the inside of the viewing window. When replacing the cover, take special care that the display legend plate is centered on the display and that the cover window lugs do not hit the legend plate in the last two or three turns of the cover.

Electrical Care of Enclosure (Flow Meter Unit)

Proper wire size or gauge selected for all connections should be the minimum allowable by your plant standards and regulations. The enclosure has limited space available for large gauge wire and we recommend no larger than 12 gauge and no smaller than 16 gauge for power and protective earth. When snaking the wires around the electronic assembly, special care should be taken of any protruding parts. The parts are capable of withstanding some abuse, but still be cautious not to force the wire through.

General Environmental Conditions for Flow Meter

Please contact Thermal Instrument if you will be operating outside of these conditions.

- Indoor and Outdoor use
- Altitude up to 2000 m (Please specify if different)
- Temperature -25°C to 60°C (-13 to 140°F) - Please specify if different
- Maximum relative humidity 80% for temperatures up to 31°C decreasing linearly to 50% relative humidity at 40°C (Please specify if different)
- MAINS supply voltage fluctuations up to $\pm 10\%$
- Overvoltage Category II
- Pollution Degree 2
- Wet locations; not submerged.
- 20 Amp Circuit Breaker Size needed for installation and disconnect
- If the flow instrument equipment is used in a manner not specified by the manufacturer, the protection provided by the equipment may be diminished.

2.1 Installation / Mounting of Flow Meter

Verify the Dimensions of the Flow Meter against your process connection and piping.

The Thermal Instrument Company Model 62-9 insertion probe has a variety of process mounting connections, from MNPT to welded flange, The insertion probe commonly comes with an adjustable mechanical connection which can be tightened down for permanent mounting. Verify all mounting and installation variables before tightening process packing gland.

If the installation is for Thermal Instrument Company Model 600-9 in-line flow tube design, then make certain that the pipe diameters and mounting sections are verified.

Verify the Flow Direction for the Flow Meter and Proper Placement

The 62-9 insertion probe has an indexing arrow on the flat portion of the process connection located just below the base of the enclosure. On Model 600-9 it will be on flow element body. See Figure Below.

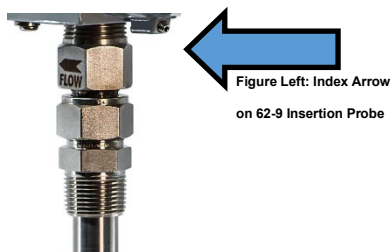

Figure Left: Index Arrow
on 62-9 Insertion Probe

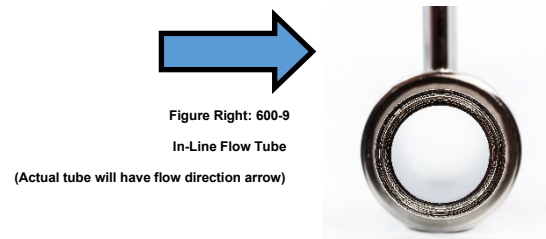

Figure Right: 600-9
In-Line Flow Tube

(Actual tube will have flow direction arrow)

Align the insertion probe during the installation so that the flat areas of the mechanical process connection with the arrow are parallel to the direction of the process flow, and the arrow points in the direction of the process flow.

For the 600-9 in-line flow tube assembly, the indexing arrow is etched on the flow tube, and should be pointing in the direction of the flow. If the flow device is not mounted in the proper direction, then there will be a reduction in accuracy.

Compression Fitting Mounting (62-9 Insertion Probe Style)

A. Determine the inside diameter of the process pipe at the pre-determined mounting location. If the Inner pipe diameter is 1-1/2" to 2", then the insertion probe will utilize the dual tip design and would be inserted to the bottom of the line and withdrawn up by 1/8". For line sizes 2-1/2" to 7", the probe would be inserted completely to the bottom of the line, and then withdrawn 1/4". For line sizes equal to or greater than 8", insert the probe halfway into the line, and then insert 3" further for optimal positioning.

Compression Fitting Mounting (62-9 Insertion Probe Style)(Continued)

- B.** Once inserted into the line at the proper positioning, tighten down the connection to ANSI B16.5 torque specifications. Make sure that proper thread sealants are applied prior to torque down of the fitting.
- C.** Adjust the probe so that the flats of the mechanical process gland are parallel with the flow and that the indexing arrow is also in the direction of the flow path.
- D.** Once the insertion length and probe positioning are correct, tighten the mechanical gland assembly using two wrenches with one on the smaller connection and the other on the larger connection. Do not over tighten by more than one and one half turn. The mechanical packing gland assembly can be readjusted if needed.

NPT Pipe Thread Mounting (62-9 Insertion Probe Only)

- A.** Make certain that a proper environmental sealant is applied to the process threads of the insertion probe prior to installation and tightening into line.
- B.** Make certain that the conduit is not rotated more than 180° with the insertion probe fastened to the process line as the RTD (Resistance Temperature Detector) wires could be damaged.
- C.** The threads on the insertion probe are right-handed and should not be over tightened or cross threaded as this can cause moisture to leak out or ingress.

Flanged Mounting (62-9 Insertion Probe Only)

- A.** Make certain that the proper sized flow meter flange and ANSI rating is correct for the mating process side of the flange. Verify the line pressure vs. the overall flange rating.
- B.** Make certain that a new gasket is available for the flange connection and that the area on the process flange side is cleaned and free of any raised areas that could be a leakage path for media inside the line.
- C.** Prior to fastening the flanges together, make sure that the indexing arrow is parallel with the flow direction.
- D.** Carefully mount the flow meter with the flange to the process side flange and use the bolts with nuts to secure the flanges together.

2.2 9500P Integral Electronics Design

The Model 9500P transmitter / electronics is available as an integral design. The integral design features the transmitter / electronics mounted atop the insertion or in-line flow style sensors.

2.3 9500P Remote Electronics Design

The Model 9500P transmitter / electronics is also available as a remote mounted design whereby the transmitter / electronics can be remotely located up to 2000 feet from the sensing element via interconnecting cable. This remote mount version then comprises the 9500P transmitter / electronics in the remote area and a junction box enclosure with a wiring terminal block mounted atop the sensing element or probe design.

2.4 Insertion Style Probes Model 62-9

For installation of the 62-9 insertion probe, the 10 upstream and 5 downstream conditions still apply. The insertion probe must be rotated so that the index arrow etched on the probe is facing towards the flow of the media.

Thermal Instrument Company has two styles for the insertion probes; one is the dual tip which is most often applied for lines smaller than 2" and the second design is the single piece machined probe, which is available in 1/2", 3/4" or 1" OD size or greater. The size of the probe is determined by the flow velocity of the media as well as the application parameters like operating pressure. In **Figure X & Y** below, we show the insertion probes for the single piece machined probe and the dual tip design.

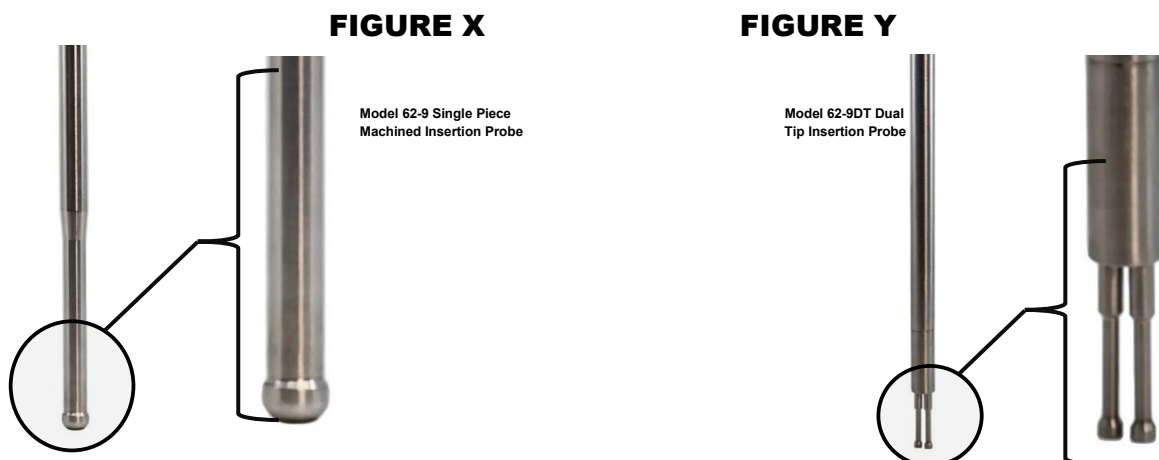

2.5 Proper Sealing of the Transmitter / Electronics

Prior to mounting the insertion style probe into the tube or pipeline, make certain that there is a proper seal applied to the process connection. If the process connection is an NPT style, then Teflon tape or a liquid style sealant is applied. If the connection on the probe is a flange or other type of surface connection, then an appropriate gasket material should be in place between the probe connection and the pipe mounting section.

Additionally, the conduit seals on the transmitter / electronics enclosure should also be done properly so that no external moisture can penetrate the threaded area. Also, be certain to tighten down the enclosure cover for the integral / compact transmitter and / or remote junction enclosure and remote mounted transmitter / electronics. Thermal Instrument Company is not responsible for any 9500P transmitter, junction enclosure, or external equipment damage due to negligence on improper sealing of any conduits going to the enclosures or the enclosure covers not being secured with the O-ring gasket on the base of the transmitter / electronics.

Packing Glands

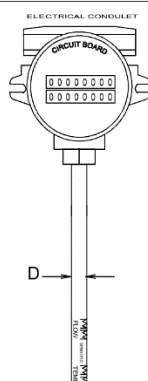



Diagram illustrating the probe assembly and packing gland configurations. The probe assembly includes an electrical conduit, a circuit board, and a probe body with diameter D. Two packing gland configurations are shown: CONAX (Pressure Above 25 PSIG) and SWAGELOK (Pressure Up to 25 PSIG).

PROBE TYPE FLOW METER DIAMETER (D)	PACKING GLAND (CONAX)	PACKING GLAND (SWAGELOK)
1/2"	2.88"	2"
3/4"	2.88"	2"
1"	3.50"	2.45"
1 1/2"	4.25"	3.5"
2"	N/A	4.47"

FEATURES:
 SIMPLE ASSEMBLY - INSERT PROBE, TIGHTEN CAP
 REPLACEABLE SEALANT PERMITS REPEATED USE OF FITTING
 STAINLESS STEEL BODY

NOTE:
 FOR 1/2 PROBE DIAMETER PACKING GLANDS, THE STANDARD SIZE THREAD IS 3/4 NPT, HOWEVER THIS CAN BE ORDERED OR ADAPTED TO 1/2" NPT OR ANY LARGER SIZE THREAD.
 FOR OTHER PROBE DIAMETERS, THE PACKING GLAND THREAD SIZE IS THE SAME AS THE PROBE DIAMETER, THUS THE 1" PROBE PACKING GLAND HAS A STANDARD 1" NPT SIZE, BUT AS WITH ALL THE PACKING GLANDS THIS CAN BE ADAPTED TO FIT OTHER CONNECTION SIZES.



Thermal Instrument Company
 217 Sterner Mill Road, Treviso, PA 19053, USA

DWG NO: Packing Gland Info 11-1-21	DESCRIPTION: PACKING GLAND INFORMATION
ORIGINATION DATE: 11/1/21	DRAWN BY: MJH APPROVED BY: MJH
SCALE: NONE	MATERIAL: A.S. NOTED PAGE: 1 of 1

Recommended Insertion Probe Installation

THE METER SHOULD BE INSTALLED IN A STRAIGHT LINE. THIS STRAIGHT LINE SHOULD HAVE A MINIMUM LENGTH OF 10 PIPE OR TUBE DIAMETERS AHEAD OF THE METER AND 5 AFTER THE METER.

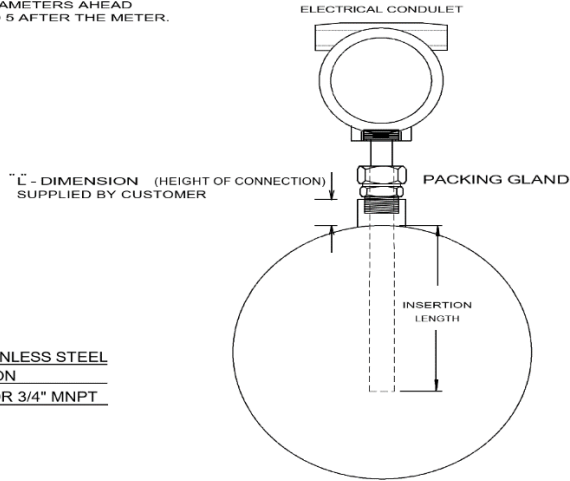

RECOMMENDED INSERTION LENGTHS

FOR LINE SIZES 1 1/2" TO 2":
GENTLY INSERT TO BOTTOM OF LINE THEN WITHDRAW 1/8",

FOR LINE SIZES 2 1/2" TO 7":
GENTLY INSERT TO BOTTOM OF LINE THEN WITHDRAW 1/4",

FOR LINE SIZES EQUAL TO OR GREATER THAN 8", INSERT HALFWAY INTO LINE THEN INSERT 3" MORE.

PACKING GLAND:
MATERIAL: STAINLESS STEEL
INSERT: TEFLON
THREADS: 1/2" OR 3/4" MNPT

PROBE DIAMETER: 1/2" O.D. / 3/4" O.D. / 1" O.D. / 1 1/2" O.D.

PROBE MATERIAL: 316 S.S.

MODEL: 62-9	PROBE INSTALLATION	THERMAL INSTRUMENT CO. TREVOSE, PA.
		DATE: 07/19/22 <small>DRAWING NO. INSTALLATION-62-RECOMMENDED LENGTHS-2</small>

ELECTRICAL CONDULET

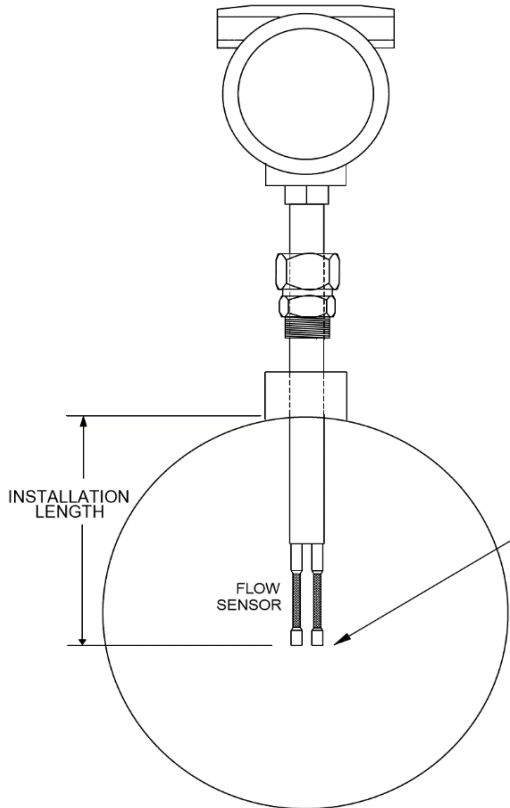

THE METER SHOULD BE INSTALLED IN A STRAIGHT LINE. THIS STRAIGHT LINE SHOULD HAVE A MINIMUM LENGTH OF 10 PIPE OR TUBE DIAMETERS AHEAD OF THE METER AND 5 AFTER THE METER.

FOR ALL LINE SIZES EXCEPT 2" AND 1 1/2"

DUAL TIP PROBE
INSTALLATION
LENGTH

POSITION BOTTOM OF THE DUAL TIPS THROUGH THE PIPE UNTIL REACHING 1/2 THE INSIDE DIAMETER PLUS 1/2"

FOR 2" SCH 40 PIPE AND 1 1/2" SCH 40 PIPE
INSERT GENTLY UNTIL TIP TOUCHES BOTTOM THEN WITHDRAW 1/8"

SERIAL NO.		Thermal Instrument Company 217 Sterner Mill Road, Trevose, PA 19053, USA	
<small>Thermal Instrument Company Proprietary Statement. This drawing is the property of Thermal Instrument Company. Unauthorized use of this document is prohibited and subject to prosecution if violated.</small>	DWG NO.: INSTALLATION LENGTH-62DT-PG	DESCRIPTION: INSTALLED DUAL TIP PROBE	
ORIGINATION DATE: 12/2/16	DRAWN BY: MJH	APPROVED BY: MJH	
SCALE: NONE	MATERIAL: 316 S.S.	PAGE: 1 of 1	

Recommended Insertion Probe Installation (Continued)

Recommended installation when customer process is known to have significant moisture in the pipe. Significant moisture is characterized by the presence of water droplets contacting the flow sensor.

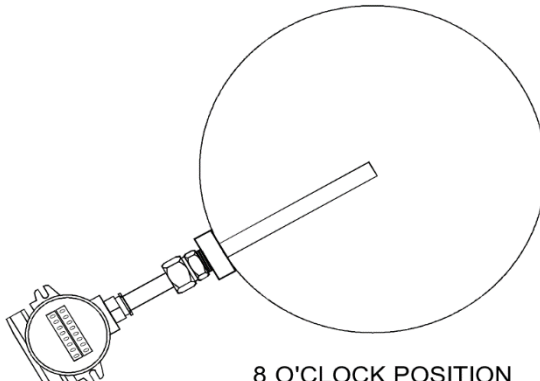

8 O'CLOCK POSITION

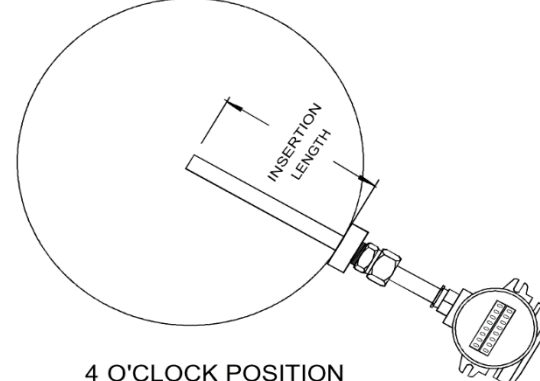

4 O'CLOCK POSITION

RECOMMENDED INSERTION LENGTHS

FOR LINE SIZES 1 1/2" TO 2":
GENTLY INSERT TO BOTTOM OF LINE THEN WITHDRAW 1/8".

FOR LINE SIZES 2 1/2" TO 7":
GENTLY INSERT TO BOTTOM OF LINE THEN WITHDRAW 1/4".

FOR LINE SIZES EQUAL TO OR GREATER THAN 8", INSERT HALFWAY INTO LINE THEN INSERT 3" MORE.

FOR HORIZONTAL FLOW

IF POSSIBLE POSITION PROBE TYPE FLOW METER TO APPROXIMATELY EITHER ANGLE.

 Thermal Instrument Company 217 Sterner Mill Road, Trevose, PA 19053, USA		
DWG NO.: INSTALLATION ORIENTATION LANDFILLS 3-12-19	DESCRIPTION: RECOMMENDED PROBE POSITION ANGLES FOR LANDFILL USE.	
ORIGINATION DATE: 3/12/19	DRAWN BY: MJH	APPROVED BY: MJH
SCALE: NONE	MATERIAL: N/A	PAGE: 1 of 1

3.0 Transmitter Information & Wiring

3.1 Operation

Flow Transducer

In this section, there will be references to functional block diagrams. See **Figure 3** for the main block diagram on page 22. The Thermal Instrument Company thermal mass flow meter utilizes a unique compound bridge circuit that measures and controls the temperature of the precision RTD that is bonded to the dry side of the media conduit.

The power required to maintain this temperature is proportional to the mass flow rate of the fluid or gas. This raw measured signal then goes through a linearization circuit to straighten the flow curve. Additionally, some method of temperature compensation must be performed on the signal.

Electronics Transmitter

The transmitter / electronics used with the majority of the flow transducers is the 9500P. This electronics has a series of printed circuit boards with interconnectivity. The mass flow measurement and functionality of the design is accomplished on the Bridge Voltage Control Board shown in **Figure 2** on page 21. The output signal is passed to the Logic Control Board where the non-linear signal is digitized. This digital value is used to look up the corresponding flow value in an EEPROM (Electrically Erasable Programmable Read-Only Memory). The linearized value is then used to drive an LED flow rate display, an 8-digit totalizer, and the analog 4 to 20 mA DC current flow signal.

The Logic Control Board incorporates a micro-processor, which controls the data flow and modifies the calculations according to parameters stored in EEPROM. The microprocessor also controls the communications link between the flow meter and a personal computer. This communication link is used to monitor and change the operating factors for the flow device.

3.2 Input Power and Output Signals

100—240 VAC - Thermal Instrument recommends a maximum of 12-gauge and minimum of 16-gauge wiring for power and protective earth (ground). All conductors shall be copper. AC Power is connected on Power

Termination Board as shown in Section 1A.3 of manual. Thermal Instrument recommends the power source for the flow instrument use a 20 Amp Circuit Breaker for disconnect purposes only.

3.2 Input Power and Output Signals(Continued)

24 VDC - (22 volts DC min, 30 volts DC max) - Thermal Instrument recommends a maximum of 12-gauge and minimum of 16-gauge wiring for power and protective earth (ground). All conductors shall be copper. DC Power is connected on Power Termination Board as shown in Section 1A.3 of manual. Thermal Instrument recommends the power source for the flow instrument use a 20 Amp Circuit Breaker for disconnect purposes only.

Output Signals

Terminals are provided for local instrument powered two-wire signals (positive and common). If the Temperature Transmitter option has been provided, a single wire common connection may be used or two-wire cables may be run. There are protective Poly Switch breakers on the output signal lines and they will “open” up if overloaded, but circuits can still be damaged. When power is on if there is zero output current (there should be at least 4 mA even through a current meter) disconnect the field wiring and check the terminal block points for a voltage. Presence of a voltage (typically 20 to 30 volts) with no current flow indicates that the Poly Switch breakers have been tripped. Power must be turned off if the Poly Switch breakers are tripped in order for them to reset. They do not need to be replaced as a fuse. Maximum load resistance is 500 ohms.

Flow - The 4-20 mA flow signal is at Terminal Block 2, the positive connection on point 1 (at the top of Block 2) and the negative on point 2. The output current signal is a 4 mADC at zero flow and 20 mADC at 100% of rated flow.

Temperature (optional) - The 4-20 mA temperature signal is at Terminal Block 3, the positive connection on point 1 (at the top of Block 3) and the negative on point 2.

Totalizer Pulse Output - The 9500 pulse output's standard configuration is 12 Volt DC pulse with a 20 millisecond on time and 1 pulse per specified flow range. The three variables are, 1 - Voltage pulse or dry contact closures output, 2 – Length of pulse 20 millisecond standard can be shorter or longer. (Example: 5 millisecond, 100 millisecond, 1 second, Etc.) 3 - Pulses per unit of Flow rate, example: 1 pulse per flow unit, 10 pulses per flow unit. The three variables are not field changeable therefore Thermal Instrument needs to know what the variables are to accommodate the equipment interface.

Start-up Operation - With all connections having been completed and tested, a short but fast flow rate should be obtained in order to clean gas bubbles and impurities from the flow tube.

CAUTION - Flow and transducer must be within 50°C (122°F) of operating temperature before power is applied. Sensors may be damaged if transducer temperature is below this limit and/or calibration may not be accurate. Apply power and allow a 10-minute warm-up period.

3.3 Continued Operation

Electronics Unit Field Service Details

Terminal Board

Figure 2 (Pg.21) shows the component configuration for the two field wiring boards.

Figure 3 (Pg.22) shows the block diagram. All field wiring is made to the terminal board.

There are two (optionally three) terminal blocks. Connect the input power to the three-position block TB1 according to TIC-436-2 on the field wiring diagram. Terminal Block TB2 carries the 4-20 mADC flow signal and, if optionally ordered, TB3 carries the 4-20 mADC signal for the specified temperature range. Both current signal require a loop with a maximum resistance of 500 ohms. The signals are powered by the internal electronics and must not be connected to an external power supply. (NOTE: Hart & Modbus options may require 24 VDC external power source)

Flow Bridge Voltage Control Board

The flow bridge voltage control board controls the flow transducer sensor and provides the non-linear flow signal to the logic board. In calibration, the potentiometer R2 is set to balance the temperature sensor with the flow sensor at the lowest temperature in the application range. A second pot, R11 is set to balance the bridge at the high extreme of the application temperature range. These two adjustments are determined in calibration and should NOT be changed.

Logic Board

The logic board converts the non-linear analog flow signal to a digital value, determines the linear equivalent from the data stored in an Electronically Erasable Programmable Read Only Memory (EEPROM), runs an 8-Digit totalizer and outputs the linear flow data as an analog signal (4 to 20 mADC) and a 5-1/2 digit flow rate display.

R6 is adjusted so that the voltage on TB5 pin 1 is equal to the zero flow voltage from the flow bridge. Adjustment is then made to R7 so, when the maximum voltage is applied to the S+ input, the voltage at TB5 pin 3 equals 4.096 volts. Potentiometer R17 provides the 4 mA adjustment for the output current signal.

Access to Menu System & Resetting Totalizer is done on the Logic Board

To Reset Totalizer Display to “0”. Press and hold the black push button (See Figure 3 on Page 21) labeled (SW4) in for 5 seconds until display flashes. Totalizer has been reset at this point.

See Addendum for additional information on the Integral Menu System.

Figure 2 - Components of Field Wiring Boards

**9500P Bridge Voltage
Control Board**

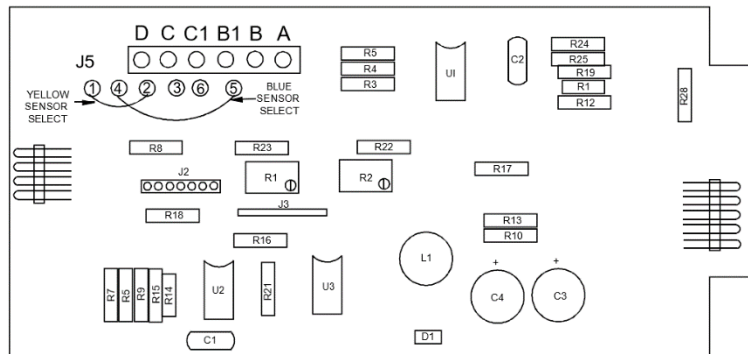

**9500P Logic Board
with optional Hart or
Modbus RS485 Output**

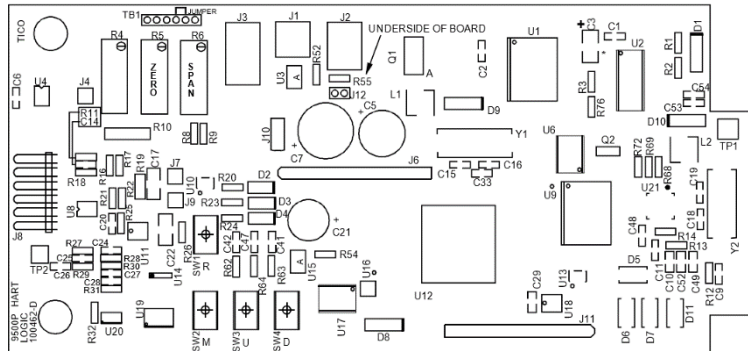

**9500P Logic Board with
Internally Powered
4-20mA Output**

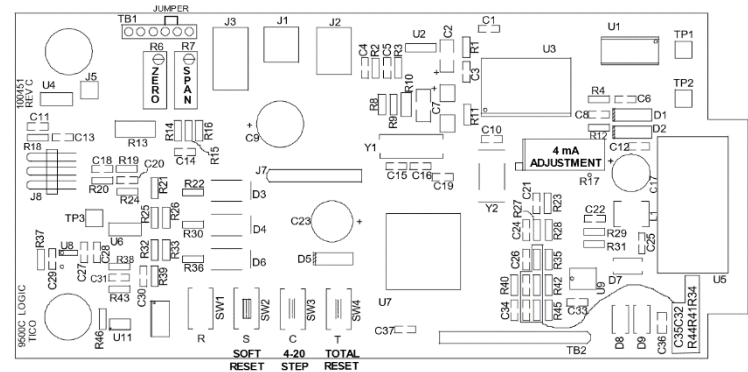

Figures for Electrical Diagrams from Previous Page

Figure 3 - Block Diagram

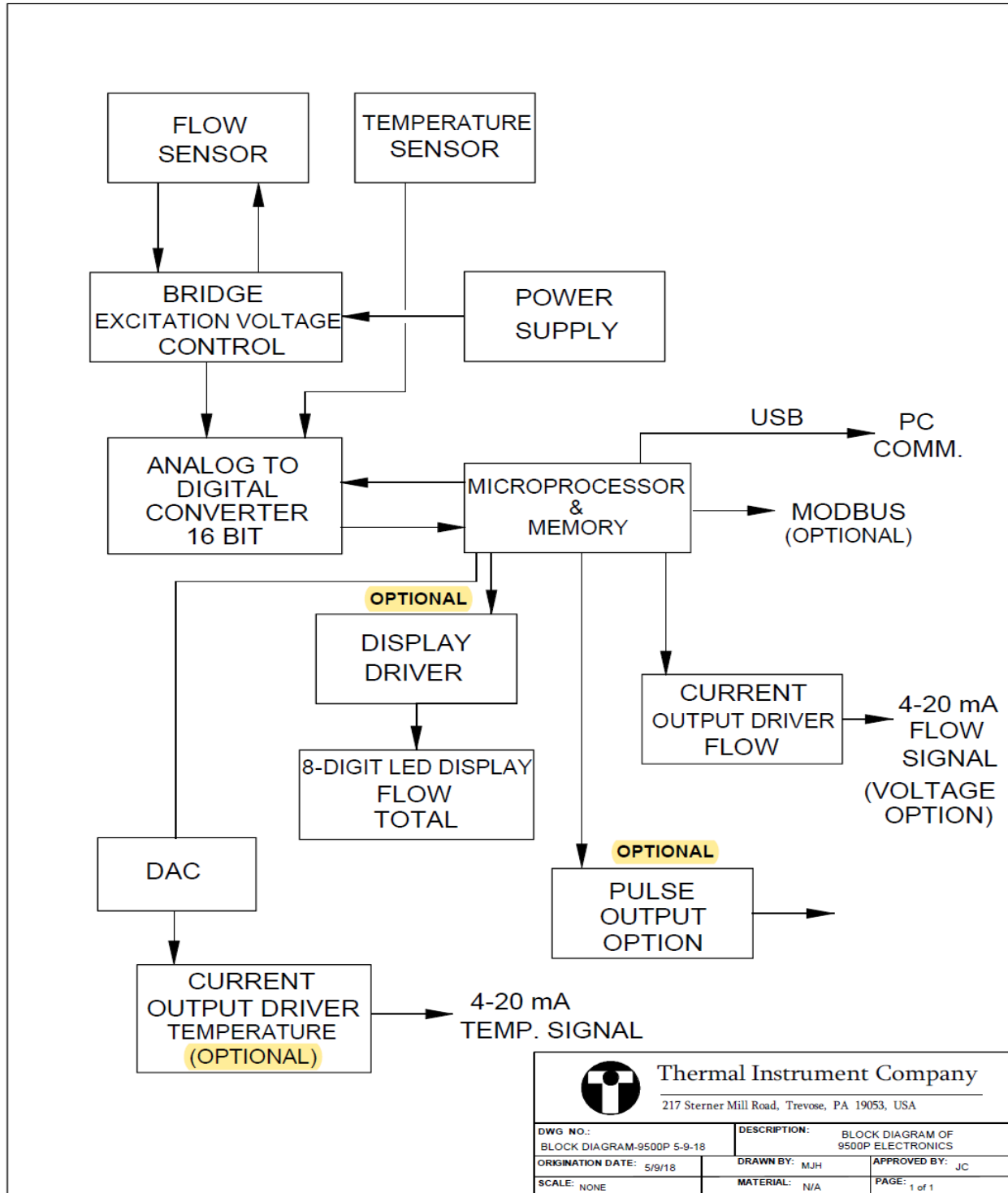

General Precautions to be Observed in Installing Flowmeter Wiring

When the Thermal Flowmeter or Probe is supplied with an explosion-proof conduit, it must be installed with approved wiring techniques. This calls for seals where the external wiring enters these condulets.

In the case where we have a large conduit on a Probe with multiple connections, we will have a fitting with as large as a 2-inch pipe connection. If the contractor is reducing this 2-inch fitting, he must be sure that these reducers are sealed with a suitable electrical or Teflon tape. In like manner, the connectors he uses must be of the sealed conduit type.

Water entering the system from either the power wiring or the interconnecting cable system is very serious and can do damage to the metering system.

The explosion-proof type condulets are designed, water will enter. In applications where there is undue exposure, it may be well to go to auxiliary covering or sealing mechanisms. This may merely mean a plastic coating, a plastic bag, or in extreme cases a housing.

The same rules apply also where the external wiring enters the electronic housings. These can be either the explosion-proof type, or NEMA 4 type. In either case adequate attention must be paid to sealing the electrical incoming lines. The cover on the NEMA 4 case is gasketed in a very adequate manner. However, in many cases the atmospheric and liquid leaks are at the point of entry of the external wiring or through the conduit from the external wiring itself.

In cases where the NEMA 4 units are used in very hazardous or corrosive atmospheres, it is advisable to purge the system to prevent corrosive attack on the electronics.

General Precautions to be Observed in Installing Flowmeter Wiring
(Continued)

The sketch below shows how commercial seals are installed.

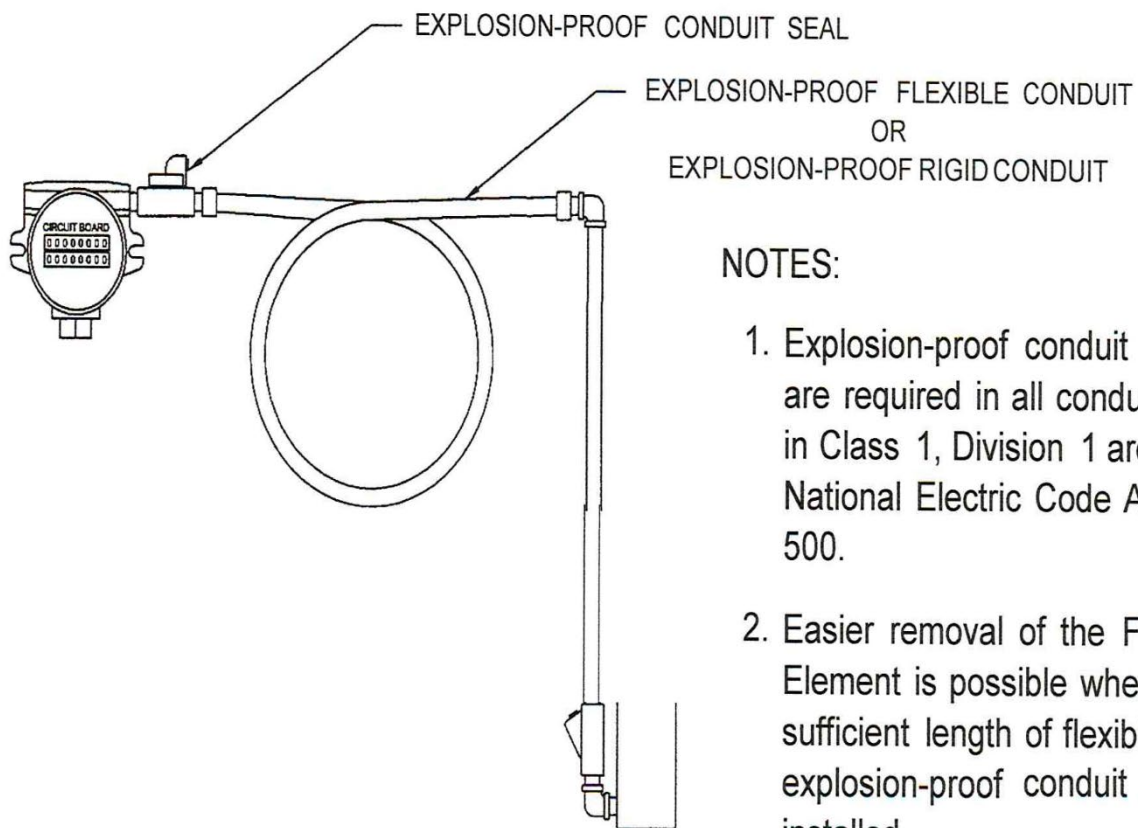

Enclosure Terminations and Seals



SEALING FITTINGS



Class I, Div. 1 & 2, Groups A, B, C, D
Class I, Zone 1, Groups IIC, IIB, IIA
Class II, Div. 1 & 2, Groups E, F, G
Class III

FEATURES-SPECIFICATIONS

Application & Installation Class I, Divisions 1 and 2

The purpose of seals in a Class I hazardous location is to minimize the passage of gases and vapors and prevent the passage of flames from one electrical installation to another through the conduit system. Seals are required to be installed within 18 inches on any conduit run entering an enclosure which contains devices that may produce arcs, sparks, or high temperature. Where two enclosures are connected by a run of conduit not over 3 ft. long, a single seal located at the center of the run is considered satisfactory. Only explosionproof unions, couplings, elbows, and conduit bodies similar to "L", "T", and "X" type shall be permitted between the sealing fitting and the enclosure.

Seals shall be located within 18 inches of the enclosure or fitting on each conduit run of 2 inch size or larger entering an enclosure or fitting that contains terminals, splices, or taps.

Each run of conduit from a hazardous location to a nonhazardous location should be sealed to minimize the amount of gases and vapors communicated beyond the seal.

Class II, Divisions 1 and 2

Where a raceway provides communication between an enclosure which is required to be dust-ignitionproof and one which is not, suitable means shall be provided to prevent the entrance of dust into the dust-ignitionproof enclosure through the raceway.

Consideration for selection seals:

Select the proper sealing fitting for the hazardous gas/vapor involved; i.e., Class I Groups A, B, C, or D. Zone 1, Groups IIC, IIB, IIC.

Select a sealing fitting for the proper use in respect to mounting position. This is particularly critical when the conduit runs between hazardous and nonhazardous areas. Some seals are designed to be mounted in any position; others are restricted to vertical mounting.

Drains

Where there is a probability that liquid or other condensed vapor may be trapped within enclosures for control equipment or at any point in the raceway system, approved means – such as installation of drain seals – shall be provided to prevent moisture accumulation.

For more complete data or special applications, consult the code or your local inspector.

Sealing compounds shall be approved for the purpose and shall not be affected by the surrounding atmosphere or liquids, and shall not have a melting point of less than 93°C. (200°F.).

In the complete seal, the minimum thickness of the sealing compound shall not be less than the trade size of the conduit, and in no case less than 5/8 inch.

NOTE: The amount of Killark sealing compound and packing fiber required for any seal is determined by volume, hub size and mounting position of the seal. Refer to installation data table on page F50 for specific amounts required.

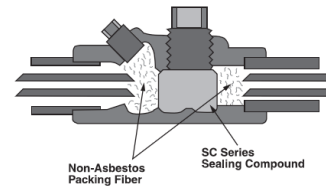

Schematic drawings illustrate the application of sealing compound, fiber dams, and installed seal with drain.

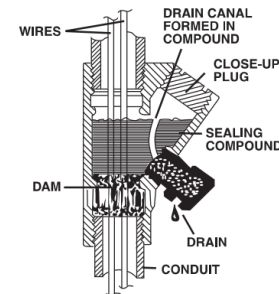

Splices and taps shall not be made in fittings intended only for sealing with compound, nor shall other fittings in which splices or taps are made be filled with compound.

Killark sealing fittings are produced with utmost care to insure a substantial margin of safety. Threads are clean, deep, and snug. When properly installed with Killark sealing compound (SC Type) and Killark non-asbestos fiber (PF Type) for the dams, you can be sure your installation will provide more than adequate safety.

Enclosure Terminations and Seals



SEALING FITTINGS



ENY-1, 2, 3, 4, 5, 6
 Class I, Div. 1 & 2, Groups A, B, C, D
 Class I, Zone 1, Groups IIC, IIB, IIA
 Class II, Div. 1 & 2, Groups E, F, G
 Class III

EYS Series
 Class I, Div. 1 & 2, Groups C, D
 Class I, Zone 1, Groups IIB, IIA
 Class II, Div. 1 & 2, Groups E, F, G
 Class III

File No. E10514
 Certified File No. LR11716
 See files for details or call Killark.

FEATURES-SPECIFICATIONS

Material/Finish

Copper-free Aluminum
 (less than 4/10 of 1%)

- Electrostatically applied powder coating

Duraloy Iron

- Tri-Coat Finish of electrozinc, chromate sealant, and electrostatically applied powder coating

HUB SIZE	ENY SEALING FITTINGS				TURNING RADIUS	ENY WITH NIPPLE	
	CATALOG NUMBER		DIMENSIONS			CATALOG NUMBER	
	KILLARK ALUMINUM	DURALOY IRON	A	B		KILLARK ALUMINUM	DURALOY IRON
1/2"	ENY-1	ENY-1M	4-1/16" (103)	1-9/32" (33)	1-3/32"(30)	ENY-1-T	ENY-1TM
3/4"	ENY-2	ENY-2M	4-3/16" (106)	1-1/2" (38)	1-9/32"(33)	ENY-2-T	ENY-2TM
1"	ENY-3	ENY-3M	5" (127)	1-3/4" (45)	1-13/32"(36)	ENY-3-T	ENY-3TM
1-1/4"	ENY-4	ENY-4M	5-3/8" (137)	2-3/16" (56)	1-25/32"(45)	ENY-4-T	ENY-4TM
1-1/2"	ENY-5	ENY-5M	5-11/16" (144)	2-3/8" (60)	1-29/32"(48)	ENY-5-T	ENY-5TM
2"	ENY-6	ENY-6M	6-3/8" (162)	2-3/8" (60)	2-5/16"(59)	ENY-6-T	ENY-6TM

Dimensions

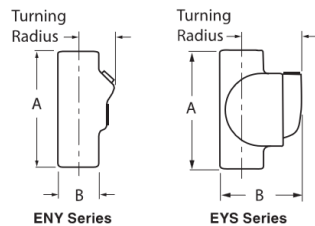

HUB SIZE	EYS SEALING FITTINGS				TURNING RADIUS	EYS WITH NIPPLE	
	CATALOG NUMBER		DIMENSIONS			CATALOG NUMBER	
	KILLARK ALUMINUM	DURALOY IRON	A	B		KILLARK ALUMINUM	DURALOY IRON
1/2"	EYS-1	—	2-15/16" (75)	1-13/16" (46)	1-3/16" (30)	EYS-1-T	—
3/4"	EYS-2	—	4-1/16" (103)	2-1/16" (52)	1-9/32"(33)	EYS-2-T	—
1"	EYS-3	—	4-25/32" (121)	2-11/32" (60)	1-13/32"(36)	EYS-3-T	—
1-1/4"	EYS-4	—	5-3/8" (137)	3" (76)	1-25/32"(45)	EYS-4-T	—
1-1/2"	EYS-5	—	5-11/16" (144)	3-1/4" (83)	1-29/32"(48)	EYS-5-T	—
2"	EYS-6	—	6-3/8" (162)	3-15/16" (100)	2-5/16"(59)	EYS-6-T	—
2-1/2"	EYS-7	EYS-7M	7-5/8" (194)	4-1/2" (114)	4-1/8" (105)	EYS-7-T	EYS-7TM
3"	EYS-8	EYS-8M	7-5/8" (194)	4-1/2" (114)	4-3/8" (111)	EYS-8-T	EYS-8TM
3-1/2"	EYS-9	EYS-9M	7-1/8" (181)	5-3/16" (132)	4-3/4" (121)	EYS-9-T	EYS-9TM
4"	EYS-0	EYS-0M	7-1/8" (181)	5-3/16" (132)	4-3/4" (121)	EYS-0-T	EYS-0TM

KILLARK®

WWW.HUBBELL-KILLARK.COM



F47

Enclosure Terminations and Seals



SEALING FITTING



EY & EYD Series
 Class I, Div. 1 & 2, Groups C, D
 Class I, Zone 1, Groups IIB, IIA
 Class II, Div. 1 & 2, Groups E, F, G
 Class III

UL File No. E10514
 Certified File No. LR11716
 See files for details or call Killark.

FEATURES-SPECIFICATIONS

Material/Finish

Copper-free Aluminum
 (less than 4/10 of 1%)

- Electrostatically applied powder coating
- **Duraloy Iron**
- Tri-Coat Finish of electrozinc, chromate sealant, and electrostatically applied powder coating

HUB SIZE	EY SEALING FITTINGS					EY WITH NIPPLE	
	CATALOG NUMBER		DIMENSIONS		TURNING RADIUS	CATALOG NUMBER	
	KILLARK ALUMINUM	DURALOY IRON	A	B		KILLARK ALUMINUM	DURALOY IRON
1/2"	EY-1	EY-1M	3-1/16"(78)	2-3/4"(70)	2-1/4"(57)	EY-1-T	EY-1TM
3/4"	EY-2	EY-2M	3-1/16"(78)	2-3/4"(70)	2-1/4"(57)	EY-2-T	EY-2TM
1"	EY-3	EY-3M	4-9/32"(109)	3-1/8"(79)	2-3/8"(60)	EY-3-T	EY-3TM
1-1/4"	EY-4	EY-4M	5-1/8"(130)	3-7/8"(98)	2-7/8"(73)	EY-4-T	EY-4TM
1-1/2"	EY-5	EY-5M	5-1/8"(130)	4-5/8"(117)	3-7/16"(87)	EY-5-T	EY-5TM
2"	EY-6	EY-6M	5-1/8"(230)	5-11/16"(144)	4-1/4"(108)	EY-6-T	EY-6TM
2-1/2"	EY-7	EY-7M	7"(178)	6-5/16"(160)	4-5/8"(117)	EY-7-T	EY-7TM
3"	EY-8	EY-8M	7"(178)	6-5/16"(160)	4-5/8"(117)	EY-8-T	EY-8TM
3-1/2"	EY-9	EY-9M	8-3/4"(222)	7-1/8"(181)	5-3/8"(138)	EY-9-T	EY-9TM
4"	EY-0	EY-0M	8-3/4"(222)	7-1/8"(181)	5-3/8"(138)	EY-0-T	EY-0TM

Dimensions

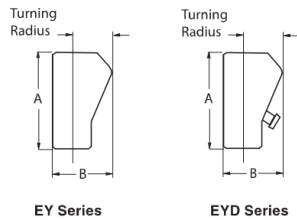

HUB SIZE	EYD SEALING FITTINGS					EYD WITH NIPPLE		
	CATALOG NUMBER		DIMENSIONS		TURNING RADIUS	CATALOG NUMBER		
	KILLARK ALUMINUM	DURALOY IRON	A	B		KILLARK ALUMINUM	DURALOY IRON	
1/2"	See New 1/2", 3/4", 1" Drain Seal offering on page F50							
3/4"								
1"								
1-1/4"	EYD-4	EYD-4M	5-1/8"(130)	3-7/8"(98)	2-7/8"(73)	EYD-4-T	EYD-4TM	
1-1/2"	EYD-5	EYD-5M	5-1/8"(130)	4-5/8"(117)	3-7/16"(87)	EYD-5-T	EYD-5TM	
2"	EYD-6	EYD-6M	5-1/8"(130)	5-11/16"(144)	4-1/4"(108)	EYD-6-T	EYD-6TM	
2-1/2"	EYD-7	EYD-7M	7"(178)	6-5/16"(160)	4-5/8"(117)	EYD-7-T	EYD-7TM	
3"	EYD-8	EYD-8M	7"(178)	6-5/16"(160)	4-5/8"(117)	EYD-8-T	EYD-8TM	
3-1/2"	EYD-9	EYD-9M	8-3/4"(122)	7-1/8"(181)	5-3/8"(137)	EYD-9-T	EYD-9TM	
4"	EYD-0	EYD-0M	8-3/4"(122)	7-1/8"(181)	5-3/8"(137)	EYD-0-T	EYD-0TM	

Enclosure Terminations and Seals



SEALING MATERIALS



Sealing Compound



Packing Fiber



Thread Lubricants

FEATURES-SPECIFICATIONS

Series SC/PF/LUBG

Sealing Materials

SC Series Sealing compound is a cement used extensively for sealing conduit to prevent the spread of explosive gases. It is non-shrinking and a secure seal is formed. SC Series resists acids, water, oil, etc. It is UL Listed for use with Killark ENY, EY, and EYS Series. Also CSA certified for use with any CSA certified sealing fitting.

Packing Fiber

Killark's Packing Fiber is made from an environmentally safe, non-asbestos material. It is easy to use and forms a positive dam to hold compound (Killark SC Type) in ENY, EY, and EYS Series fittings.

Threaded Lubricants

Two special blends of lubricants have been developed by Killark for use with threaded joints. These lubricants are to be used to prevent galling of pipe threads when threaded into a coupling, junction box, etc. They insure a quick release of undamaged male and female threads when parts are disassembled.

LUBG is a general purpose lubricant to be used in temperatures ranging from 0° to 125°F.

LUBT is a high-quality lubricant to be used in temperatures ranging from -40° to +500°F. It is recommended to be used on hazardous location lighting fixtures.

OUNCES REQUIRED PER FITTING				
HUB SIZE	SEALING COMPOUND			PACKING FIBER
	ENY [Ⓞ]	EYS [Ⓞ]	EY/EYD	
1/2"	1.5 oz.	3.0 oz.	1.0 oz.	1/16 oz.
3/4"	2.0 oz.	3.0 oz.	2.0 oz.	1/8 oz.
1"	3.0 oz.	8.0 oz.	4.5 oz.	1/4 oz.
1-1/4"	6.5 oz.	8.5 oz.	7.5 oz.	1/2 oz.
1 1/2"	8.5 oz.	17.5 oz.	12.0 oz.	1 oz.
2"	15.0 oz.	27.0 oz.	24.0 oz.	2 oz.
2-1/2"	—	42.0 oz.	44.0 oz.	3 oz.
3"	—	47.0 oz.	44.0 oz.	4 oz.
3-1/2"	—	56.0 oz.	75.0 oz.	6 oz.
4"	—	56.0 oz.	75.0 oz.	9 oz.

[Ⓞ] ENY/EYS suitable for both horizontal or vertical applications.

SEALING COMPOUND	
CATALOG NUMBER	SIZE PACKAGE
SC-4 OZ	4 oz.
SC-8 OZ	8 oz.
SC-1 LB	1 lb.
SC-5 LB	5 lbs.

PACKING FIBER	
CATALOG NUMBER	SIZE PACKAGE
PF-2	2 oz.
PF-4	4 oz.
PF-16	1 lb.

THREAD LUBRICANTS	
CATALOG NUMBER	CONTAINER PACKAGE
LUBT-2	2 oz.
LUBG-6	6 oz.

Enclosure Terminations and Seals

15599 Sec.10 12/9/01 11:21 AM Page 296



Explosionproof and Dust-tight Fittings and Accessories

EXPLOSIONPROOF AND DUST-TIGHT SEALING FITTINGS CLASS I, GROUPS B*, C & D; CLASS II, GROUPS E, F & G; NEMA 7 & NEMA 9



XYB-XYBM



Sealing Fittings are required in Hazardous Locations and are used to isolate arc-producing devices in conduit and wiring systems, and to prevent the passage of explosive pressures from one area to another.

FOR HORIZONTAL AND VERTICAL MOUNTING - Type XYB and XYBM are suitable for either horizontal or vertical mounting and are provided with threaded plugged openings into which fiber and cement can be placed to form effective seal. XYB has female ends for conduit entrance. The XYBM has female ends with a removable threaded nipple.

*1/2", 3/4", 1" sizes Class I, Group B, C, D, Class II, E, F, G.

1 1/4", 1 1/2", 2", 2 1/2", 3", 3 1/2", 4" sizes Class I, Group C, D, Class II, E, F, G

- CSA Certified LR27991
- UL Listed E10493

10A-4

Catalog No. Description	Conduit Size (In.)	Ounces Req. For Each Sealing Fitting		Standard Package	
		Cement	Fiber	Qty.	Tot. Wt. Lbs.
Female-Female					
XYB-2	1/2	1	1/8	5	2.1
XYB-3	3/4	2	1/4	5	2.6
XYB-4	1	3	1/4	5	3.7
XYB-5	1-1/4	6	3/8	2	2.5
XYB-6	1-1/2	9	1/2	2	3.2
XYB-8	2	18	3/4	2	5.6
XYB-10	2-1/2	23	1-1/2	2	6.2
XYB-12	3	48	3-1/8	1	6.0
XYB-14	3-1/2	70	4-1/2	1	6.8
XYB-16	4	90	6	1	8.3

Catalog No. Description	Conduit Size (In.)	Ounces Req. For Each Sealing Fitting		Standard Package	
		Cement	Fiber	Qty.	Tot. Wt. Lbs.
Male-Female					
XYBM-2	1/2	1	1/8	5	2.2
XYBM-3	3/4	2	1/4	5	2.7
XYBM-4	1	3	1/4	5	3.8
XYBM-5	1-1/4	6	3/8	2	2.6
XYBM-6	1-1/2	9	1/2	2	3.4
XYBM-8	2	18	3/4	2	5.9
XYBM-10	2-1/2	23	1-1/2	2	6.8
XYBM-12	3	48	3-1/8	1	6.3
XYBM-14	3-1/2	70	4-1/2	1	7.3
XYBM-16	4	90	6	1	8.8

Nominal Dimensions (Inches)						
Conduit Size	A	B	C	(XYBM Series Only)		Turn Radius R
				D		
1/2	3-19/32	1-13/16	5/8	11/16		1-3/16
3/4	3-25/32	2-1/16	3/4	15/16		1-5/16
1	4-3/8	2-5/16	7/8	15/16		1-7/16
1-1/4	5-5/32	2-13/16	1-1/16	1-1/16		1-3/4
1-1/2	5-11/16	3-3/16	1-3/16	1-3/16		2
2	6-13/16	3-7/8	1-1/2	1-7/16		2-3/8
2-1/2	7-1/2	4-1/2	1-7/8	1-5/8		2-11/16
3	9-9/16	5-1/2	2-3/16	1-7/8		3-5/16
3-1/2	9-1/2	6-1/6	2-3/8	2		3-11/16
4	9-9/16	6-1/2	2-5/8	2-1/8		3-7/8

Compliances

- NEC Class I, Groups B, C, D
Class II, Groups E, F, G
- UL Standard 886 - CSA Standard C22.2 No. 30

29A

Enclosure Terminations and Seals

15599 Sec.10 12/9/01 11:21 AM Page 298



Explosionproof and Dust-tight Fittings and Accessories

EXPLOSIONPROOF AND DUST-TIGHT SEALING FITTINGS CLASS I, GROUP D; CLASS II, GROUPS E, F & G; NEMA 7 & NEMA 9

Adalet Sealing Fittings are used to isolate arc-producing devices from wiring systems and to prevent the spread of explosive gases.

FOR VERTICAL MOUNTING

Types XY and XYM Fittings are for vertical mounting, and are provided with threaded plugged openings into which the sealing cement is poured. Sizes 1-1/4" x 1-1/2" have large plugged openings in the lower hub to facilitate packing fiber around the wires to form a dam. Type XYM's have removable threaded nipples. The two hubs are tapped simultaneously to assure alignment of the conduits, especially important to equipment manufacturers using short runs of conduit.

FOR HORIZONTAL & VERTICAL MOUNTING

Type XYC Fittings are for horizontal mounting only, with the cover opening in an upright position. XYCS fittings are for vertical or horizontal mounting, with removable threaded covers which can be turned to the desired position for pouring in the sealing cement. The covers are interchangeable. The male-to-female types have removable threaded nipple.



XY 2-3-4

XYM 2-3-4



XY 5-6

XYM 5-6



XYC

XYCM

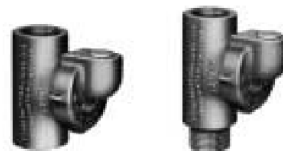

XYCS

XYCSM

10A-6

- CSA Certified LR27991
- UL Listed E10493

Compliances

- NEC Class I, Group D Class II, Groups E, F, G
- UL Standard 886 - CSA Standard C22.2 No. 30

202

Catalog Number	Conduit Size (In.)	Ounces Required per Fitting		Standard Package	
		Sealing Cement	Packing Fiber	Qty	Weight Lbs.
XY2	1/2	1	1/8	25	10
XY3	3/4	1	1/4	25	10
XY4	1	2	1/4	25	12-1/2
XY5	1-1/4	4	3/8	10	7-1/2
XY6	1-1/2	5	1/2	10	10
XYC2	1/2	2	1/8	25	13
XYC3	3/4	2	1/4	25	13
XYC4	1	4-1/2	1/4	25	15
XYC5	1-1/4	8-1/2	3/8	10	10
XYC6	1-1/2	11-1/2	1/2	10	11
XYC8	2	13-1/2	3/4	10	12
XYC10	2-1/2	15	1-1/2	1	2
XYC12	3	31-1/2	3-1/8	1	3
XYC14	3-1/2	42-1/2	4-1/2	1	4
XYC16	4	51	6	1	5
XYC2S	1/2	2	1/8	25	13
XYC3S	3/4	2	1/4	25	13
XYC4S	1	3	1/4	25	15
XYC5S	1-1/4	6-1/2	3/8	10	10
XYC6S	1-1/2	10	1/2	10	11
XYC8S	2	12-1/2	3/4	10	12
XYC10S	2-1/2	13-1/2	1-1/2	1	2
XYC12S	3	29-1/2	3-1/8	1	3
XYC14S	3-1/2	40	4-1/2	1	4
XYC16S	4	48-1/2	6	1	5

KILLARK CONDULET INFORMATION

KILLARK ENCLOSURES



HK/2HK SERIES

KILLARK

INSTRUMENT / DEVICE ENCLOSURES



HK



2HK

FEATURES-SPECIFICATIONS

Applications

Instrumentation housed in HK Series enclosures typically used to measure, detect, monitor, transmit and control industrial processes and systems.

HK Series enclosures are suitable for a broad range of applications, meeting both domestic and international code requirements.

Some specific examples of the type of instruments that can be housed in these enclosures include:

- Flow measurement devices
- Temperature monitors
- Two-wire transmitters
- Gas detectors
- Ph analyzers
- Pressure gauges
- Temperature transmitters
- Oxygen/combustible gas sensors
- Methane gas monitors
- Level detectors
- H2S monitors
- Transducers
- Pressure switches

See pages E57 - E58 for dimensions.

Features

- Enclosures are explosion proof, dust/ignition proof, weather proof and tamper resistant
- HK Series boxes covers are cast from a copper-free aluminum alloy
- Cast stainless steel box, flat & lens cover available (HKSB-BC + HKSB-GLC)
- Neoprene O-rings are provided with HK boxes to assure water resistance in NEMA 4/IP66 conditions
- Three box styles available: HKB, HKBD single cover design and the 2HKB double cover design. 2HKB enclosure has two separate chambers for isolation between

power and instrument.

- HKB, HKBD box has offset feed-thru conduit openings (3/4" NPT) for maximum use of interior volume
- 2HKB box has offset feed-thru conduit openings (3/4" NPT) on power side and one (3/4" NPT) on bottom instrument side
- Interior mounting pad for instrument/device cast into the bottom of the HKB, HKBD box is provided in an "X"-configuration for flexibility
- Location of the internal ground screw boss does not interfere with the mounting of the instrument or device
- Eight different cover styles are available: standard flat cover, standard glass lens cover, 1" dome cover, 1" dome lens cover, 2" dome cover, 2" glass lens dome cover, 4" dome cover and 4" dome lens cover.
- All covers have shrouded tamper resistant set screws as standard which can help to combat excessive vibration in rugged settings
- Lugs on cover permit easy removal and tightening

Material/Finish

- Boxes and covers – copper-free aluminum (less than 4/10 of 1%)
- HKSB series is 316 cast stainless steel
- O-ring sealing gasket – Neoprene rubber

ATEX/IECEX Certified

IECEX UL 14.0071U
 DEMKO D1 ATEX 15742U
 Ex II 2 G / D
 Ex db IIC Gb, Ex tb IIIC Db IP66
 Ta = -60°C to +70°C for GL (glass) lenses
 Ta = -60°C to +70°C for blank covers
 Class I, Div. 1 & 2, Groups A*, B, C, D†
 Class I, Zones 1 & 2, Groups IIB + H2, IIA
 Class II, Div. 1 & 2, Groups E, F, G
 Class III, Type 3, 4, 4X

UL - File E83969 & File E150827

SF - Certified - File LR11716

FM - File 1W1R4-RE



- Ground screws – zinc plated steel with green dye (Stainless steel on HKSB)
- Allen head cover screw – cadmium plated steel (Stainless steel on HKSB)
- Glass lens – 3/8" thick tempered glass
- Finish – silver powder epoxy paint, electrostatically applied
- Special colors available in quantity

* Group A FM only on HK single cover box. Order with -GA suffix.

** CENELEC on assembled HK parts only with suffix "C".

*** Seal immediately adjacent to enclosure.

† Seal within 18" of enclosure for Groups BCD and within 6" for Group A in accordance with sections 501-5 and 502-5 of the National Electrical Code.

HK Design Features

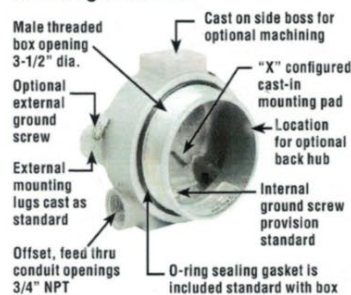

2HK Design Features



KILLARK CONDULET INFORMATION

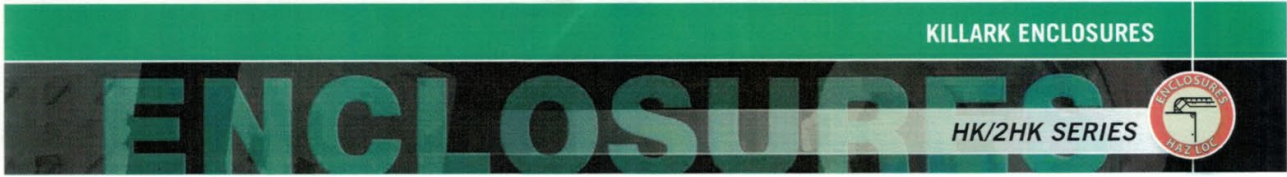

INSTRUMENT / DEVICE ENCLOSURES

Boxes



Standard Flat Covers



Dome Covers 1", 2" and 4"



FEATURES-SPECIFICATIONS

2HKB Series Boxes

The wall that separates the instrument side from the power side can be machined for slots or holes up to a maximum of two slots 5/16" by 1-1/2".

Submit drawings for machining requirements to Killark.

Factory Modifications

Approvals allow for factory or field modifications on HKB box for drilling and tapping conduit openings on side or back of enclosure without voiding UL-CSA-FM approvals. Internal mounting pad holes on "X" configured boss can be factory added by drilling from inside of box without piercing the bottom of enclosures. Assemblies with ATEX/IEC Ex approvals must be factory modified in order to comply with certifications.

HK ASSEMBLED PARTS					
CATALOG NUMBER (CAST ALUMINUM)					
HKB BOX & COVERS		HKBD BOX & COVERS	2HKB BOX W / BLANK COVER ON POWER SIDE & OPTIONAL COVER ON INSTRUMENT SIDE		COVER TYPE
UL-CSA-FM APPROVED	CENELEC UL-CSA-FM APPROVED	UL-CSA-FM APPROVED	(UL-CSA-FM)	CENELEC UL-CSA-FM APPROVED	
HKB-B	HKB-BC	HKBD-B	2HKB-B-B	2HKB-BC-BC	Standard flat
HKB-2D	HKB-2DC	HKBD-2D	2HKB-B-2D	2HKB-BC-2DC	2" Dome
HKB-4D	HKB-4DC	HKBD-4D	2HKB-B-4D	2HKB-BC-4DC	4" Dome
HKB-GL	HKB-GLC	HKBD-GL	2HKB-B-GL	2HKB-BC-GLC	Lens
HKB-2GLD	HKB-2GLDC	HKBD-2GLD	2HKB-B-2GLD	2HKB-BC-2GLDC	2" Dome lens

HK COMPONENT PARTS	
CATALOG NUMBER	DESCRIPTION
HKB	Single cover box only
HKBD	Single deep box only
2HKB	Double cover Box only
HFC	Flat cover
HKGL	Lens cover
HK1D	1" Dome cover
HK1GLD	1" Dome lens cover
HK2D	2" Dome cover
HK4D	4" Dome cover
HK2GLD	2" Dome lens cover
HK4GLD	4" Dome lens cover
1572LABB	Rep. "O" Ring Gasket

HKSB STAINLESS STEEL ASSEMBLED PARTS	
HKSB BOX & COVERS CENELEC UL-CSA-FM APPROVED	COVER TYPE
HKSB-BC	Standard flat
HKSB-GLC	Lens

HKB FACTORY MODIFICATIONS	
CATALOG SUFFIX	DESCRIPTION
-01 -	1/2 NPT hub in back
-02 -	3/4 NPT hub in back
-10 -	1/2 NPT hub in side
-20 -	3/4 NPT hub in side
-21 -	3/4 NPT hub in side 1/2 NPT hub in back
-22 -	3/4 NPT hub in side 3/4 NPT hub in back
-02S -	3/4 NPSM hub in back
-22S -	3/4 NPT hub in side 3/4 NPSM hub in back
-2S0 -	3/4 NPSM hub in side
-2S1 -	3/4 NPSM hub in side 1/2 NPT hub in back
-2S2 -	3/4 NPSM hub in side 3/4 NPT hub in back
-GS -	External ground screw (Standard on HKB assembly with CENELEC approvals)
-GA -	Group A - FM approval (Available only on HKB box furnished with covers installed)
-SU93 -	Unpainted - Natural finish
-SU9 -	Special colors of powder paint available in quantity. Consult factory for details

- ① Assemblies that are CENELEC approved include as standard:
 - External ground screw with terminal
 - Pre-drilled nameplate holes and screw on pad for customer installed nameplate.
- ② See information at right for optional factory machining.
- ③ Product is stocked at component level. Recommend ordering as such for reduced lead time.
- ④ 2HKB Assemblies include a flat cover on power side, dome and lens covers can be substituted in place of flat cover, consult factory for ordering details.
- ⑤ Not FM Approved

Ordering examples:
 Modified box component HKB-20
 Modified assembly HKB - B - 20 OR HKB - BC - 20



KILLARK CONDULET INFORMATION

KILLARK ENCLOSURES



HK SERIES

KILLARK

INSTRUMENT / DEVICE ENCLOSURES



HK



HKSB - Stainless Steel

FEATURES-SPECIFICATIONS

Dimensions
 Note: Add 1/2" to all depth dimensions when using HKBD Deep Box.
 HKBD volume = 33 cu.in.

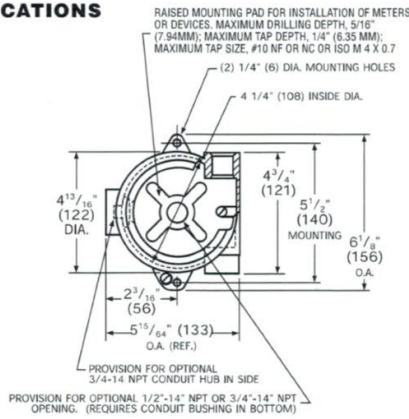

HKB Volume: 31 cu. in.

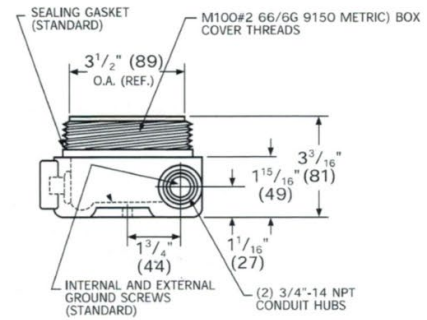

HKB box and blank cover

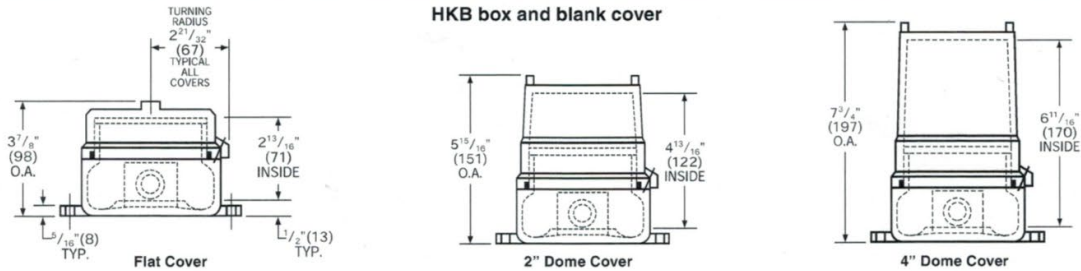

HKB box and glass lens cover

For HK1GLD (1" Dome Lens Cover), add 1" to lens cover verticle height dimensions

For HK4GLD (4" Dome Lens Cover), add 2" to 2 dome lens cover verticle height dimensions

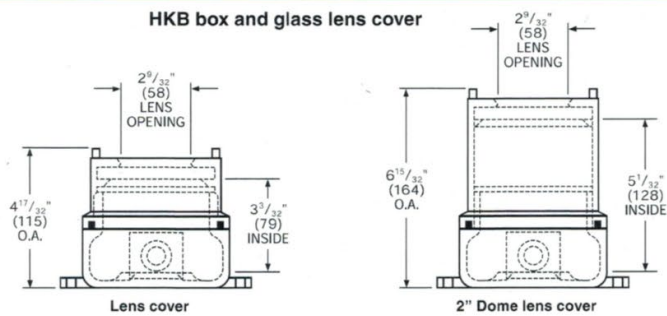

E56

KILLARK

WWW.HUBBELL-KILLARK.COM



KILLARK CONDULET INFORMATION



INSTRUMENT / DEVICE ENCLOSURES



2HK

FEATURES-SPECIFICATIONS

Dimensions

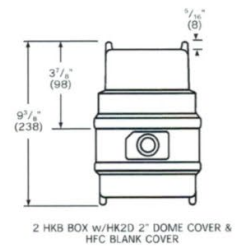
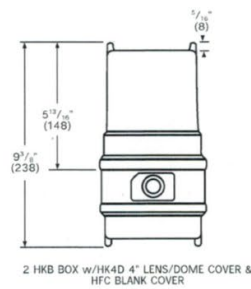
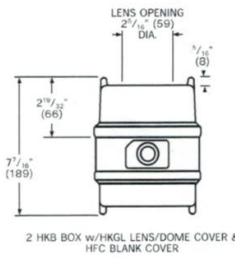
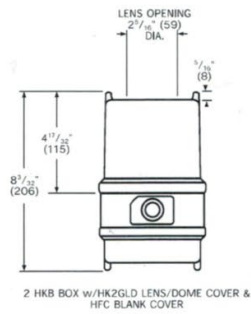
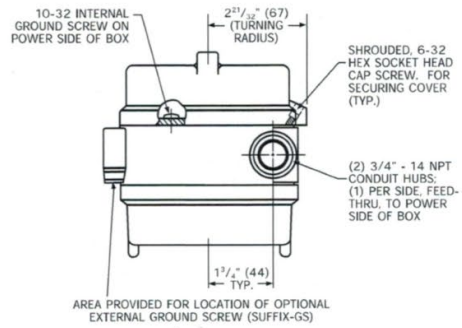
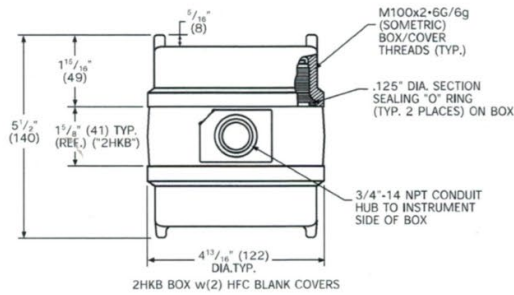

FLOW ELEMENT CONDULET USED ON REMOTE 9500P

31.03.2016

Limatherm S.A.



INSTRUMENT HOUSING – type XD-I

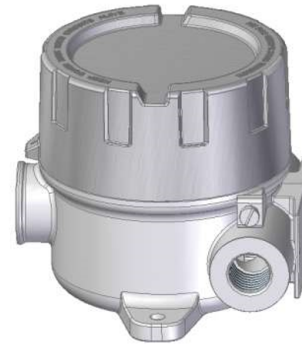
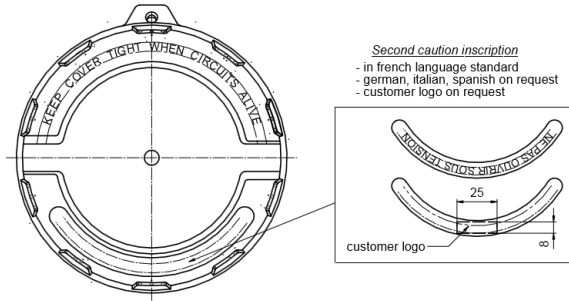
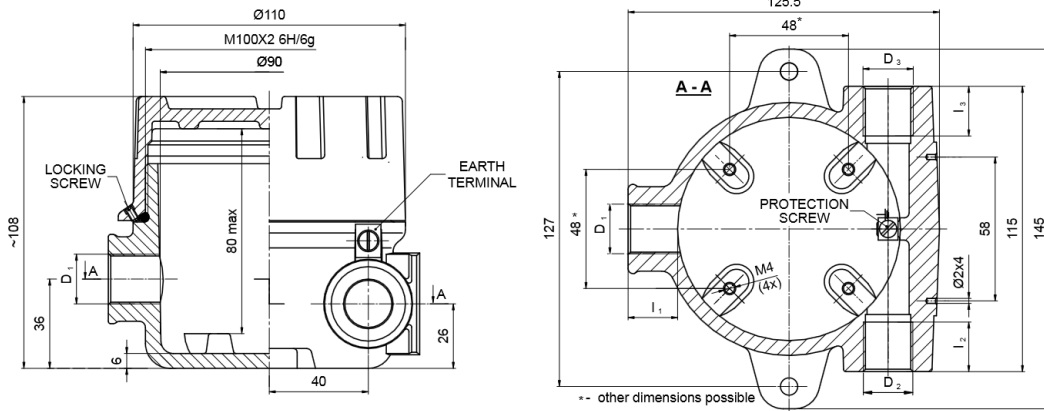

FOR ALL VERSIONS of XD-I							
Material of body and cover: aluminium pressure die-casting							
Service temperature: T _{serv} = -40 + 100°C (85°C with window) – oil proof rubber							
T _{serv} = -40 + 100°C (85°C with window) – silicone rubber							
T _{serv} = -20 + 200°C (85°C with window) – FKM rubber							
Coating: yellow chromating and chemically resistant paint (outside only)							
THREAD D ₃	I ₃ [mm]	THREAD D ₂	I ₂ [mm]	THREAD D ₁	I ₁ [mm]	SEAL MATERIAL	COATING
M20×1.5 M24×1.5 M25×1.5	20	M20×1.5 M24×1.5 M25×1.5	20	M20×1.5 M24×1.5 M25×1.5 M27×2	20	3	SE
½ NPT mod ¾ NPT mod	16	½ NPT mod ¾ NPT mod	16	½ NPT mod ¾ NPT mod	16	4 5	Cal SPU PPU P
PD		PD		PD			

PROTECTION CONCEPT

Protection method	Type of protection		Permitted use	Approval Body	Certificate No.	Protection Principle
	ATEX marking	IECEx marking				
Flameproof EN 60079-0 EN 60079-1 EN 60079-31 IEC 60079-0 IEC 60079-1 IEC 60079-31	1026 II2G Ex db IIC Gb	Ex db IIC Gb	Zone 1, Zone 2 Zone 21, Zone 22	FTZU Czech Republic	FTZU 03 ATEX 0207U IECEx FTZU 12.0017U	Contain the explosion and quench the flame

34-600 LIMANOWA, ul. Tamowska 1;

tel. +48 18 337 98 20

fax +48 18 337 98 25

www.limatherm.com

Field Calibration Check Procedure for 9500P Electronics

The 9500P electronic signal conditioner output can be checked by simulating the voltage output of the Flow sensor with an external DC voltage source.

1. Turn off power to flow meter
2.
 - A. For Integral 9500P:
 - a. Remove push-on jumper across pins 4 and 5 of TB1 (located above Zero and Span Pots on Logic Board as shown below).
 - b. On TB1, connect an external variable DC voltage source, negative to Pin 2 and positive to Pin 5 (pin 1 is closest to the front).
 - B. For Remote 9500P:
 - a. Disconnect cable from electronics terminal TB2 (Located on board opposite side of the Logic Board).
 - b. Connect an external variable DC voltage source to terminal TB2, negative to terminal 2 and jump it to 3. Connect the positive to terminal 4.
3. Apply power to the electronics.
4. Locate the calibration specification sheet in the instruction manual labeled "Component Values Determined at Calibration".
5. Turn on variable DC voltage source and set DC voltage to the 10% of full-scale flow rate transducer voltage (EXC). The display, if available, should indicate the 10% of full-scale flow rate. The DC mA Output should be 5.6mA (10% of scale). If the mA output is not correct, adjust ZERO potentiometer R6 until 5.6 mA.
6. Set the DC voltage to the 90% of full-scale flow rate transducer voltage (EXC). The display, if available should indicate the 90% of full-scale flow rate. The DC mA output should be 18.4 mA. If the mA output is not correct, adjust SPAN potentiometer R7 until 18.4 mA. You may have to return to step #6 if any adjustments were made due to the ZERO and SPAN potentiometers adjustments offset each other a little.
7. After the 10% and 90% of full-scale flow rates are checked, check 0, 20, 30, 40, 50, 60, 70, 80, and 100% points.
8. Turn off power to the DC Voltage Source and flow meter.
9. Disconnect the DC Voltage Source.
10.
 - A. For Integral 9500P, place jumper back on across pins 4 and 5 on TB1.
 - B. For Remote 9500P, reconnect the cable to electronics terminal TB2.
11. Turn on power to flow meter.
12. If procedure does not prove satisfactory, recheck steps taken and if necessary, contact Thermal Instrument Company for assistance.

Parameter Setup Utility (PSU) Instructions for Thermal Instrument Flow Meters

Loading PSU onto your machine:

Copy PSU Setup.exe file from the flash drive provided, click on the link provided in an email, or type this link into your web browser:

https://www.thermalinstrument.com/tiuploads/psu/install/psu_setup.exe

Clicking the above link will start downloading the software from the TIC secured site. Note: After initial download and set up, the software will retrieve any updates to the PSU software tool when your machine is connected to the internet and the PSU tool is launched on your device.

- Click and open the program “PSU_Setup.exe”
- You should have a screen that looks like this once it downloads and installs on your machine:

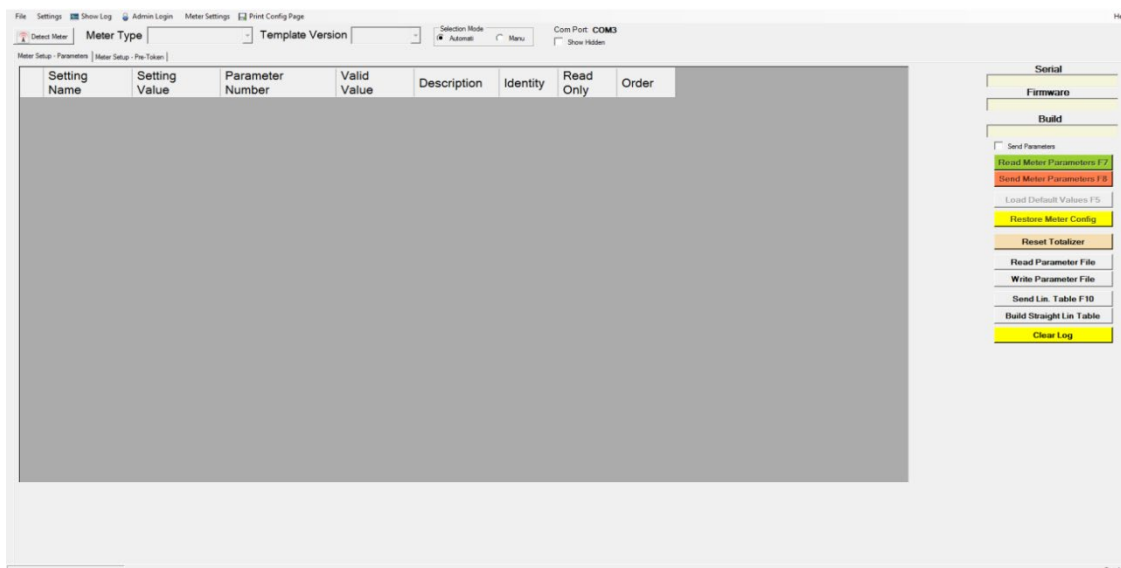

- To adjust parameters on your flow meter, you need to unlock specific fields. Open file named “9500_FS16_All.ick” that you received in the flash drive or email. Save that file to your desktop or some other folder that can be easily accessed.
- Go back into Parameter Setup Utility File.
 - Go to FILE (Top Left part of Screen)
 - Navigate down to Import Token Unlock File
 - Navigate to the file on your PC where you saved it, select file, and click OPEN.
- Restart Parameter Setup Utility.
- Power up your flow meter.
- You are now ready to plug into your meter and begin modifying or viewing current settings.
- Connect the USB end of the adaptor into the computer and connect the micro USB end of the cable into Flowmeter’s micro USB port. This connection can be viewed on next page.

- Click on “Detect Meter” on top left of screen. This will display the current flowmeter configuration. Note: If a Window Appears that says the operation has timed out your machine may not recognize the COM port. You will have to set up a COM port. Go to *Settings -> Options -> Click on Button that looks like Radio Tower at top left*. This will list available COM ports. Select one, go back to main screen, and click “Detect Meter”. If this fails unseat all cable connections and re-connect them back together.

Fields that can be Adjusted:

Note: After each parameter has been changed, select button on right side of screen “Send Meter Parameters F8” to update electronics.

- **Flow Rate Decimal Point** - This can be adjusted to show how many places after decimal point can be viewed on the Flow Rate line.
- **Flow @ 20 mADC** - NOTE: The 20mA full scale flow value cannot be lower than 10% of original full scale flow rate. The 20mA value cannot be increased above original factory set point. It can be lowered to provide greater resolution.
- **Filter Factor** - Value can be increased or decreased to help with “noisy” signal.
- **Totalizer Decimal Point** - Same as Flow Rate Decimal Point description above.
- **Zero Cutoff** - User can vary the point on the flow curve where the flow rate goes to “0” (4 mA). This value is typically set anywhere from 1% to 8% of full-scale flow rate.
- **Flow Factor** - Flow (K) Factor can be used if gas type is changing. Contact TIC for assistance in determining this value.
- **Pipe ID** – Enter the new line ID in inches. The new data will be sent to electronics and the flow rates will be calculated using the new line size data. **Note: This option only valid on Model # 62-9 Insertion Probes.**
- **Reset Totalizer** - Located on right side of screen. Follow instructions in prompt after selecting this option.

Modbus Only Options:

Note: Below Parameters can be modified to match up with customer control system.

- **Modbus Baud Rate**
- **Modbus Parity**
- **Modbus Float Order**
- **Modbus Slave ID**

Connector on 9500P:

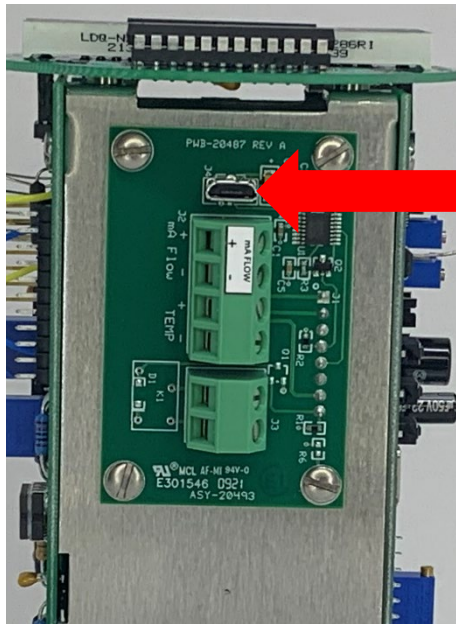

For Meters Modbus/Pulse Output (9500M):

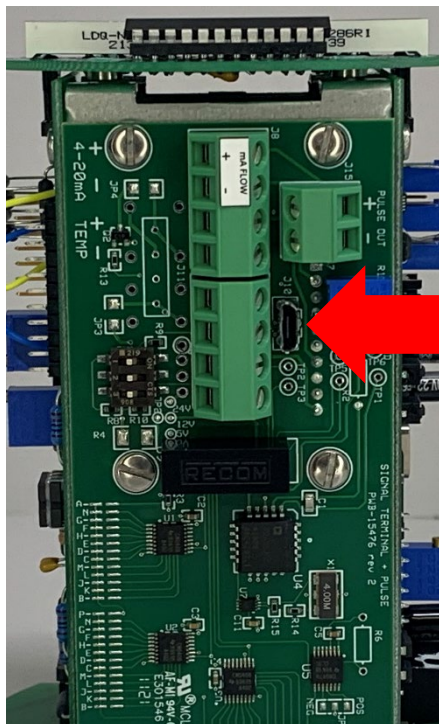

Troubleshooting

Troubleshooting of a malfunctioning flow meter is a process of isolating the particular circuit area which is out of range and then finding the components causing the failure. Before looking into the possible circuit problems, it will be profitable in most cases to first determine that the problem is NOT internal to the electronics. As odd as it may seem, most apparent flow meter malfunctions are a result of incorrect installation or changes in process operating conditions.

Typical installation problems are as follows:

- Fluid not flowing properly through pipe
- Flow rate for the temperature is out of calibration range
- Fluid not identical to calibration fluid (Example: Air instead of CO₂ or Water instead of Glycol)
- Fluid has coated the flow element (Example: Very dirty gas or liquid that leaves a film or layers)
- Flow element installed too close to upstream or downstream flow disturbance (Minimum 10 pipe diameters upstream and 5 pipe diameters downstream)
- Power not on or incorrect voltage (Example: Connecting 24 VDC in place of the 110 VAC)
- Flow element wiring incorrect
- Output wiring incorrect

For installations that had been operating correctly it is frequently helpful to review the above list since changes made to the process, piping, or wiring have been known to effect flow meter performance.

If a problem has been identified from the above list and cannot be corrected, it will be helpful to discuss the situation with Thermal Instrument Company for possible solutions (new calibration or meter modifications).

Troubleshooting(Continued)

Model 9500P Logic Board button layout:

1. Remove Lid from Electronics Condulet.
2. When facing Electronics locate the three black push buttons located on the right side of electronics.
3. Reset Meter – Soft reset of meter electronics.
4. Cycle Button – Step thru 4-20mA and other meter settings.
5. Reset Totalizer – Hold button in for 5 seconds until display flashes and totalizer resets.

Reset Meter using the top button.

Step through 4 to 20 Output using middle button. (**Cycle Button**)

Reset Totalizer holding in bottom button for 5 seconds.

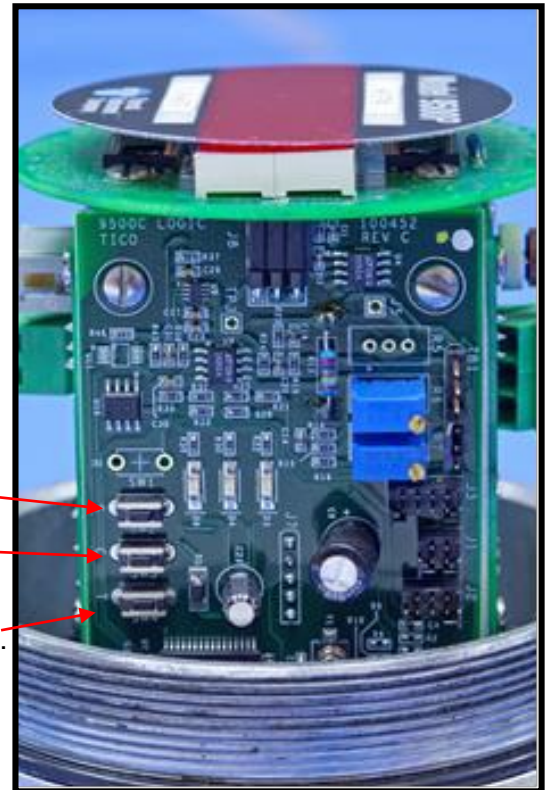

9500P Cycle Button:

- 1) 4 mA – 0%
- 2) 8 mA – 25%
- 3) 12 mA – 50%
- 4) 16 mA – 75%
- 5) 20 mA – 100%
- 6) E1 = "B" Voltage
 - a) ~ 24 VDC (For 24 VDC powered meters)
 - b) ~ 28 VDC (For 110 VAC powered meters)
- 7) E2 =
- 8) E3 = EXC Voltage
- 9) E4 =

Troubleshooting(Continued)

Model 9500H and 9500M Logic Board button layout:

1. Remove Lid from Electronics Condulet.
2. When facing Electronics locate the four black push buttons located on the right side of electronics.
3. RESET METER – Soft reset of meter electronics.
4. MENU BUTTON - Enters into meter menu system.
5. RESET TOTALIZER – Press “Menu Down” button and hold down for 5 seconds.

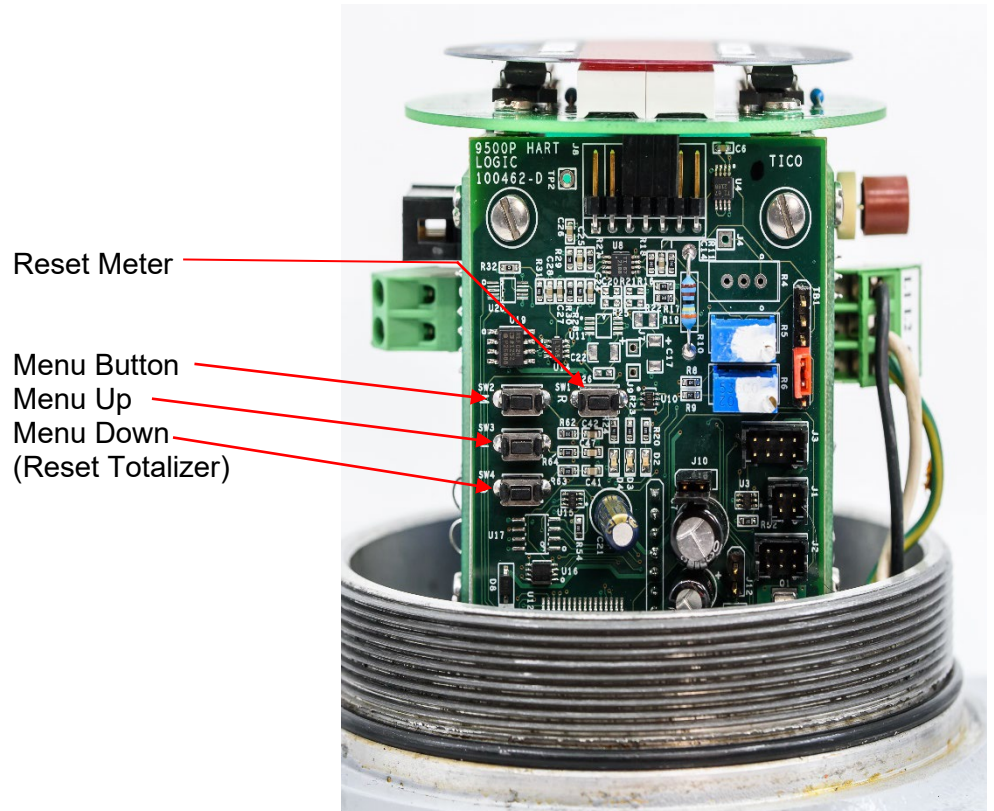

Troubleshooting(Continued)

Description of Levels & Items

Level 1 – Display Meter Info

- Item 1 - View S/N
- Item 2 - View Firmware Version
- Item 3 - View Build Number
- Item 4 - View Filter Factor
- Item 5 - View Zero Cutoff %
- Item 6 - View Flow Factor
- Item 7 - View Flow 20 MA
- Item 8 - View Pipe ID
- Item 9 - View Modbus Slave ID
- Item 10 - View Meter Multiplication (Factory Set)

Level 2 – Fixed Output Current

- Item 1 – Set 4 mA
- Item 2 – Set 8 mA
- Item 3 – Set 12 mA
- Item 4 – Set 16 mA
- Item 5 – Set 20 mA

Level 3 – Read Internal Voltage

- Item E1 – View 24 Voltage
- Item E2 – View 5.3 Voltage
- Item E3 – View Excitation Voltage
- Item E4 – Not Used

Level 4 – Change Filter Factor

- Item 0 - no filter
- Item 1 - 1/16 second
- Item 2 - 1/8 second
- Item 3 - 1/4 second
- Item 4 - 1/2 second
- Item 5 - 1 second
- Item 6 - 2 seconds
- Item 7 - 4 seconds
- Item 8 - 8 seconds
- Item 9 - 16 seconds
- Item 10 - 32 seconds
- Item 11 - 1 minute
- Item 12 - 2 minutes
- Item 13 - 4 minutes
- Item 14 - 8 minutes
- Item 15 - 16 minutes
- Item 16 - 32 minutes

Troubleshooting(Continued) Description of Levels & Items

Level 5 – Change Zero Cutoff %

- Item = % Full Scale (Display Cutoff Factor)

Level 6 - Change Flow Factor (K)

- Item = .4 to 2.0 (Contact Factory for factor numbers)

Level 7 – Change 20 mA Full Scale

- Item = Full Scale Value (float)

Level 8 – Change Pipe ID

- Item = Pipe ID (float)

Level 9 –Change Modbus Slave ID (If Modbus equipped)

- Item = Modbus Slave ID -1 to 16

Level 10 –View only -Meter Multiplication (Factory Set)

- View Only Totalizer Value

Troubleshooting(Continued)

How to check flow meter sensors and switch to spare sensors if necessary

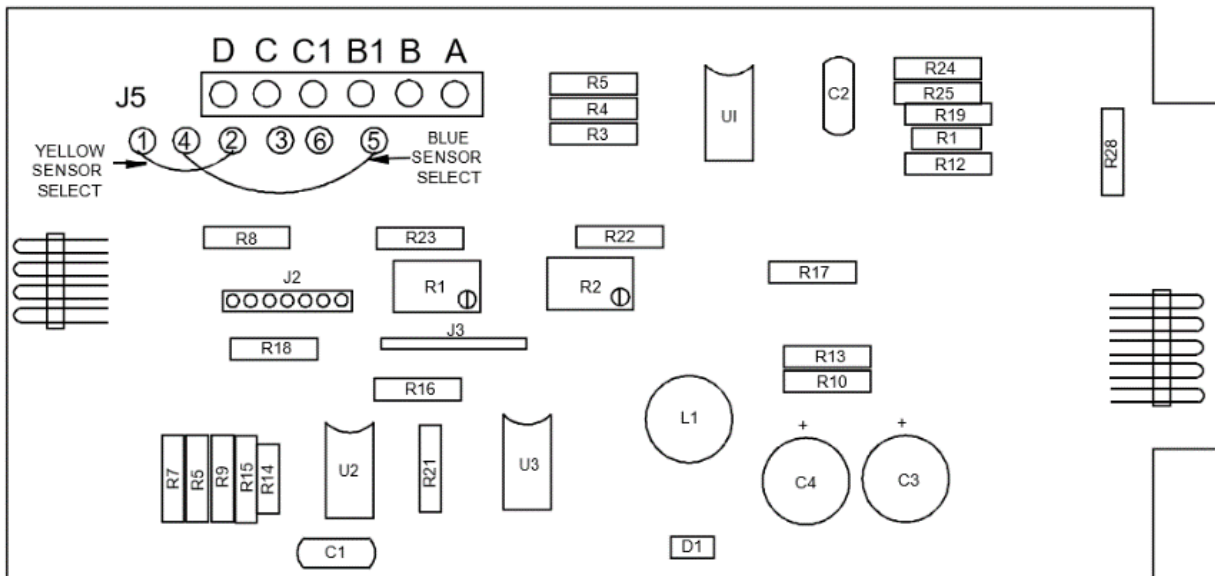

The sensors are terminated on terminal strip J5.

Sensor resistance at **75°F** in Ohms approximate:

Primary Flow:	A-B \approx 50 Ω
Spare Flow:	A-B1 \approx 50 Ω
Primary Temperature:	C-D \approx 100 Ω or 110 Ω
Spare Temperature:	C1-D \approx 100 Ω or 110 Ω

To measure sensor resistance:

1. Power meter off
2. Use Ohm meter to measure between
 - Primary Flow sensor A-B will read \approx 40 Ω to 45 Ω
 - Spare Flow sensor A-B1 will read \approx 50 Ω
 - Primary Temperature sensor C-D will read \approx 41 Ω to 48 Ω
 - Spare Temperature sensor C1-D will read \approx 100 Ω to 110 Ω

(Resistance will vary with temperature and the primary sensors in-circuit will be lower value)

To connect Spare Flow, unsolder the blue jumper wire from B (5) and move it to B1 (6)

To connect Spare Temperature, unsolder the yellow jumper wire from C (2) and move it to C1 (3)

There is no need to change to spare sensors unless primary sensors are open or shorted.

The flow signal can be read at terminals D (+) and terminal A (-) with a digital voltmeter. This voltage can be located and read as flowrate from the Parts List or Flow Curve for the serial number unit in the manual.

If there are any questions about measured flowrate voltage and output, contact Thermal Instrument Co.

Troubleshooting(Continued)

The below steps should be followed if you have Remote 9500P Electronic Transmitter Having eliminated external failure causes, check the following:

1. The Flow Element and the Electronics are a matched set. Make sure both have the same Serial Number before being connected together via cable.
2. Check the flow element power supply voltage and its polarity from the remote electronics to the flow element. This should be around 27 VDC \pm 5 VDC. The power supply is across pins 1 (+) and 2 (-) at the flow element and the remote electronics. If this voltage is zero, then disconnect the cable going to the flow element and measure the power supply again at the remote electronics. If it is still zero volts, then the problem is the remote electronics (check the main power supply and the fuse or contact Thermal Instrument Company).
3. Measure the flow element signal voltage across the pins 3 (-) and 4 (+) at the flow element and the remote electronics. This is the raw DC voltage signal coming from the flow element to the remote electronics. This voltage will vary depending on the flow rate. This voltage should be within the calibrated range specified in the calibration specification sheet located in the flow meters operating manual labeled, "Component Values Determined at Calibration" or look at the meter's graph "Transducer Voltage vs. Flow Rate". If this voltage is too low around 1 VDC or too high around 18 VDC, then the problem is the flow element.

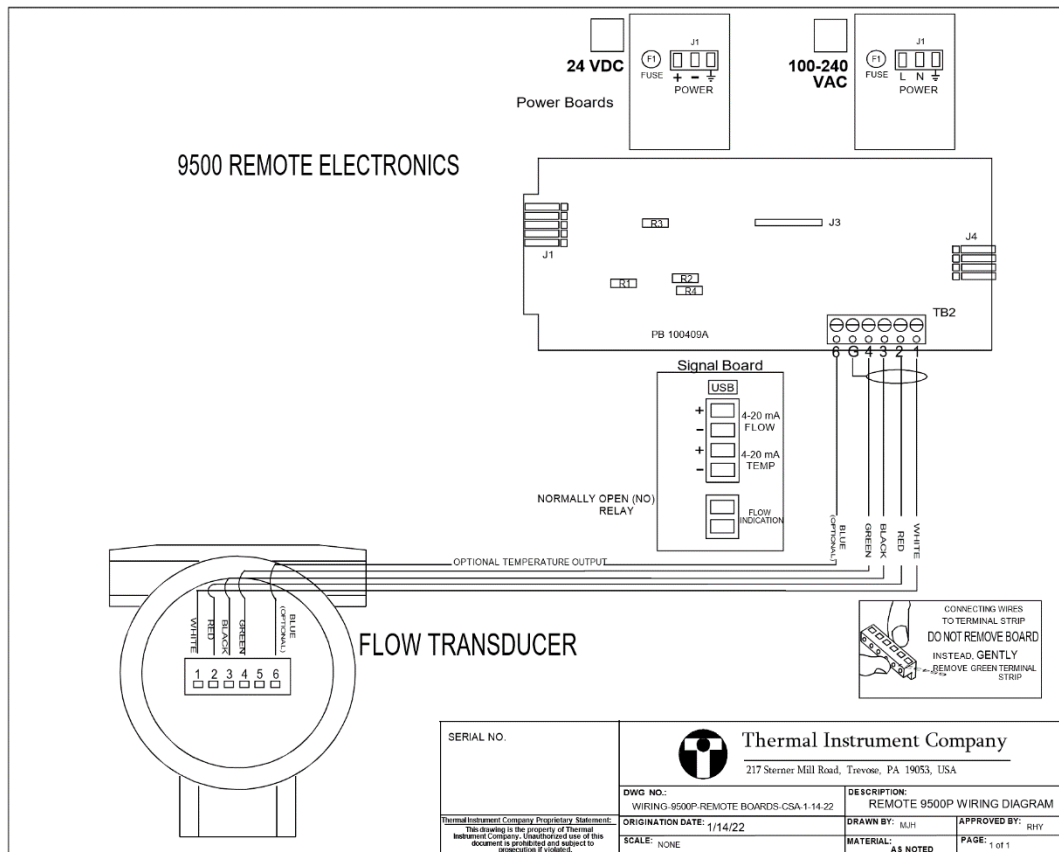

Summary

If you have any questions at all for Thermal Instrument Company, please do not hesitate to contact us at **(215) 355-8400**.

Spare Parts List:

100/240 VAC Fuse

They are readily available from Digi-Key (**1-800-344-4539**) as Part Number **WK4041BK-ND** or any other electronic supplier handling **Wickmann TR5 Sub-Miniature Fuses (UL 248-14)** or equivalent.

24 VDC Fuse

Wickmann Littelfuse 1 Amp Slow Blow 250 VAC - Digi-key Part # WK4048BK-ND.
www.digikey.com

Contact Thermal Instrument for other parts as needed.



www.ThermalInstrument.com

217 Sterner Mill Road

Trevose | PA | 19053 | USA

Phone: 215-355-8400

Fax: 215-355-1789